

MODEL



Model Sign Code

MARCH 2018

Last reviewed by LOC attorneys January 2024

MODEL SIGN CODE

Table of Contents

XX.XX.005 Title.....	3
XX.XX.010 Findings and Purposes.....	3
XX.XX.015 Definitions.....	5
XX.XX.020 General requirements.....	14
XX.XX.025 Exempt signs.....	15
XX.XX.030 Prohibited signs.....	15
XX.XX.035 Prior Lawful Nonconforming Signs.....	17
XX.XX.040 Exemptions from requirement for permit.....	21
XX.XX.045 Temporary signs.....	23
XX.XX.050 Sign districts—General.....	26
XX.XX.055 Residential sign district.....	27
XX.XX.060 Commercial sign district.....	31
XX.XX.070 Industrial sign district.....	36
XX.XX.075 Billboard districts and permits.....	38
XX.XX.080 Measurements.....	41
XX.XX.085 Projecting signs.....	44
XX.XX.090 Wall signs.....	45
XX.XX.095 Freestanding signs.....	45
XX.XX.100 Awning signs.....	46
XX.XX.105 through 115 Reserved.....	47
XX.XX.120 Construction and maintenance standards.....	47
XX.XX.125 Illumination—General restrictions.....	47
XX.XX.130 Sign permit application.....	48
XX.XX.135 Adjustments.....	52
XX.XX.140 Appeal of decision on sign permit.....	48
XX.XX.145 Inspections.....	56
XX.XX.150 Enforcement of Sign Code – General Provisions.....	57
XX.XX.155 Enforcement - Sign in public right of way or on City-owned real property.....	58
XX.XX.160 Enforcement - Sign on private property or on non-City-owned public property, other than on public right ofway.....	61
XX.XX.165 Removal of unsafe signs.....	62
XX.XX.170 Removal of abandoned signs.....	63
XX.XX.175 Reserved.....	63
XX.XX.180 Violations.....	64
XX.XX.185 Penalties and Other Remedies.....	64
XX.XX.190 Amendments.....	64

XX.XX.005 Title.

This chapter shall be known as the “[City] Sign Code.”

XX.XX.010 Findings and Purposes.

A. Findings of Fact.

1. The City Council hereby finds as follows:

- a. Exterior signs have a substantial impact on the character and quality of the environment.
- b. Signs provide an important medium through which individuals may convey a variety of messages.
- c. Signs can create safety hazards that threaten the public health, safety or welfare. Such a safety threat is particularly great for signs that are structurally inadequate, or that may confuse or distract drivers or pedestrians, or that may interfere with official directional or warning signs.
- d. Signs can also threaten the public welfare by creating aesthetic concerns and detriments to property values. Such aesthetic concerns and detriments to property values are particularly great when an accumulation of signs results in visual clutter, or when one or more signs spoil vistas or views, or when one or more signs add or increase commercialism in noncommercial areas.
- e. The ability to erect signs serving certain functions, such as an address sign or a sign announcing that the property on which it sits is for sale or for lease or a sign used to indicate areas not available (or available) for public use, is an integral part of nearly every property owner’s ability to realize fundamental attributes of property ownership. The same cannot be said for signs serving other functions, such as signs in a billboard district that are erected so as to be visible from public rights-of-way. Such signs are primarily designed to take advantage of an audience drawn to that location by the public’s substantial investment in rights-of-way and other public property.
- f. Signs serving certain other functions, such as signs that serve a purely directional function, are important because they enable visitors or residents to efficiently and safely reach their intended destinations. Experience teaches that citizens often plan as if such signs will be present in those settings, so in the absence of such signs, frustration, disorientation and disruption of intended traffic patterns may result, and time and fuel may be wasted.
- g. Only static signs (which change, if at all, only on rare occasions when they

are repainted or covered with a new picture) constitute a customary use of signage in the City.

- h. No signs that exceed the size or spacing limitations of this section constitute a customary use of signage in the City.
- i. The City's land use regulations have included the regulation of signs in an effort to foster adequate information and means of expression and to promote the economic viability of the community, while protecting the City and its citizens from a proliferation of signs of a type, size, location and character that would adversely impact upon the aesthetics of the community or threaten health, safety or the welfare of the community. The appropriate regulation of the physical characteristics of signs in the City and other communities has had a positive impact on the safety and the appearance of the community.

B. Purposes.

1. The purposes of this Code are to:

- a. Regulate signage in a manner that does not create an impermissible conflict with statutory, administrative, or constitutional standards, or impose an undue financial burden on the City.
- b. Provide for fair and consistent enforcement of the sign regulations set forth herein under the zoning authority of the City.
- c. Improve the safety and the visual appearance of the City while providing for effective means of communication and orientation, particularly in those settings in which the need for such communication or orientation is greater, consistent with constitutional guarantees and the City's Findings and other Purposes.
- d. Maintain, enhance and improve the aesthetic environment of the City, including its scenic views and rural character consistent with the purpose of each zoning district, by preventing visual clutter that is harmful to the appearance of the community, protecting vistas and other scenic views from spoliation, and preventing or reducing commercialism in noncommercial areas.
- e. Otherwise ensure that the choices for signage that are available in particular settings are compatible with their surroundings.
- f. Regulate the number, location, size, type, illumination and other physical characteristics of signs within the City in order to promote the public health, safety and welfare.

2. Because impacts of signage are often different in pedestrian-oriented areas and vehicle-oriented areas, these regulations distinguish between areas of the City designed for primarily vehicular access and areas designed for primarily pedestrian access.
3. These regulations do not seek to regulate every form and instance of visual communication that may be displayed anywhere within the jurisdictional limits of the City. Rather, they are intended to regulate those forms and instances related to structures or uses or property that are most likely to meaningfully affect one or more of the purposes set forth above.

XX.XX.015 Definitions.

For the purposes of the [City] Sign Code, unless the context indicates otherwise: words in the present tense include the future; the singular number includes the plural and the plural number includes the singular; undefined words have their ordinary accepted meaning; and, the following words and phrases mean:

“A-Frame Sign” means a double-faced temporary sign composed of two sign boards attached at the top and separate at the bottom, not permanently attached to the ground.

“Abandoned sign” means a sign or sign structure where:

- A. The sign is no longer used by the person who constructed the sign. Discontinuance of sign use may be shown by cessation of use of the property where the sign is located;
- B. The sign has been damaged, and repairs and restoration are not started within 90 days of the date the sign was damaged, or are not diligently pursued, once started.

“Alter” means to make a change to a sign or sign structure, including but not limited to, changes in area, height, projection, illumination, shape, materials, placement and location on a site. Altering a sign does not include ordinary maintenance or repair, repainting an existing sign surface, including changes of message or image, or exchanging the display panels of a sign.

“Athletic scoreboard” means a sign erected next to an athletic field by the owner or operator of the field and which is visible to spectators.

“Awning” means a shelter projecting from and supported by the exterior wall of a building constructed of rigid or nonrigid materials on a supporting framework.

“Awning Sign” means a sign attached to or incorporated into an awning.

“Balloon signs” means a sign consisting of a membrane that relies on internal gaseous pressure or a semi-rigid framework for maintaining its form.

“Banner” means a sign made of fabric or other nonrigid material with no enclosing framework.

“Beacon Sign” means any light with one or more beams directed into the atmosphere or directed at one or more points not on the same lot as the light source; also, any light with one or more beams that rotate or move.

“Bench sign” means a sign on an outdoor bench.

“Billboard” means a sign on which any sign face exceeds 200 square feet in area.

“Building elevation area” means the area of a single side of a building, measured in square feet and calculated by multiplying the length of the side of the building by the height of the building to the roof line. If the roof line height varies along the side of the building, the average of the lowest and highest roof line height on that side shall be used in the calculation.

“Building frontage, primary” means the ground floor lineal length of a building wall that faces a street, driveway, parking lot, courtyard or plaza and has an entrance or exit open to the general public.

“Building frontage, secondary” means the ground floor lineal length of a building wall that faces a street, driveway, parking lot, courtyard or plaza and does not have an entrance or exit open to the general public.

“Building official” means the building official or his or her designee.

“Bulletin board” means a permanent sign providing information in a horizontal linear format, that can be changed either manually through placement of letters or symbols on tracks mounted on a panel, or electronically, through use of an array of lights in a dot matrix configuration, from which characters can be formed.

“Business complex” means a development consisting of one or more lots sharing appurtenant facilities, such as driveways, parking and pedestrian walkways, and is designed to provide varied products and services at a single location.

- A. “Major business complex” means a development consisting of single or multiple principal uses and where the building(s) contain a minimum of 45,000 square feet in gross floor area.
- B. “Minor business complex” means a development consisting of a minimum of six principal uses and where the building(s) contain a maximum of 44,999 square feet in gross floor area.
- C. “Industrial/research business complex” means a development consisting of a minimum of six principal uses and where the building(s) contain a minimum of 100,000 square feet of gross floor area.

Comment: This definition would mean a development of less than six “principal uses” and less than 45,000 square feet would not be treated as a “business complex” for purposes of sign regulation.

“Canopy” means a permanent roofed structure which may be freestanding or attached to a building, but which is not a completely enclosed structure or awning.

“Clearance” means the distance between the average grade below a sign to the lowermost portion of the sign.

“City” means the City of **[name of City]**.

“City engineer” means the city engineer or his or her designee. “City Manager” means the City Manager or his or her designee.

Comment: Modify this definition here and throughout the code to refer to the highest decision-making authority of the sign code within the jurisdiction, e.g., Planning Director, Community Development Director, City Manager. Note: If the jurisdiction does not consider the sign code to be a land use regulation, but has members of the Planning Department also administer the sign code, the drafter should consider use of the term “City Manager” as inclusive of city staff generally, and thus not necessarily because of the staff’s planning position.

“City recorder” means the city recorder or his or her designee.

“Commercial Speech” means any sign wording, logo or other representation advertising a business, profession, commodity, service or entertainment for business purposes.

“Community event” means an activity or event identified as such by the city council.

“Component” means, when used in describing a sign, any element of a sign or its source of support (excluding a building), including but not limited to support structure, accessories, wiring, or framing. Paint, vinyl, paper, fabric, lightbulbs, diodes, or plastic copy panels on a sign do not constitute components.

“Dwelling” means any building or portion thereof that contains living facilities, including provisions for sleeping, eating, cooking and sanitation.

“Dynamic Element” means any characteristic of a sign that appears to have movement or that appears to change, caused by any method other than physically removing and replacing the sign face or its components, except through the operation of moving, rotating, or otherwise animated parts. This definition does not include Video Signs or Tri-vision Signs as defined below. This definition includes a display that incorporates a technology or method allowing the sign face to change the image without having to replace the sign face or its components physically or mechanically. This definition also includes any flashing, blinking, or animated graphic or illumination, and any graphic

that incorporates LED lights manipulated through digital input, “digital ink” or any other method or technology that allows the sign face to present a series of images or displays.

“Filing” means depositing a document in the United States mail, postage prepaid and accurately addressed to the city, or leaving a copy with the city recorder at City Hall during work hours. For purposes of this chapter, a document is “filed” on the date it is received at City Hall.

“Fire marshal” means the fire marshal or his or her designee.

“Flag” means any fabric, bunting or other lightweight material that is secured or mounted so as to allow movement caused by the atmosphere.

“Flashing” means, when used in describing a sign, the presence of an intermittent or flashing light source (whether on the face or externally mounted), or the presence of a light source which creates the illusion of intermittent or flashing light by means of animation.

“Freestanding sign” means a sign wholly supported by integral pole(s), post(s), or other structure or frame, the primary purpose of which is to support the sign and connect it to the ground. Examples include monument signs and pole signs. A freestanding sign does not include a portable sign.

“Government Sign” means a sign that is constructed, placed or maintained by the federal, state or local government for the purpose of carrying out an official duty or responsibility or a sign that is required to be constructed, placed or maintained by a federal, state or local government either directly or to enforce a property owner’s rights.

“Grade” For freestanding signs, “grade” means the average level of the ground measured five feet from either end of the base of the sign, parallel to the sign face. For signs mounted on buildings, grade means the average level of the sidewalk, alley or ground below the mounted sign measured five feet from either end of the sign face.

“Grave marker” means a sign on a cemetery plot or space, including any floral displays or other decorations placed upon it.

“Ground-mounted sign” means a freestanding sign with a minimum of 12 inches of vertical solid base directly and continuously connected to at least 50 percent of the sign face width or, is borne by two or more supports which are a minimum of 12 inches but less than eight feet above grade.

“Handheld sign” means a hand-carried sign of six square feet or less in area, worn or carried by a person when being displayed.

“Hearing Body” means the **[commission or other body that hears appeals of sign code permits]** of the City.

“Height” means the vertical distance measured from grade to the highest attached component of a sign including the supporting structure.

“Historical or landmark marker” means a sign constructed in close proximity to a historic place, object, building, or other landmark recognized by an official historical resources entity, where the sign is constructed by the owner of the historic property and does not exceed 20 square feet in size.

“Historical sign” means a sign designated as a historic or cultural resource under city, state or federal law or a sign that is an historical element of an historical landmark.

“Holiday lights or mini lights” means light fixtures that use bulbs that are sized C6, C7, or C9 or LED bulbs that are 8 mm or smaller.

“Illuminated sign” means a sign illuminated by an internal light source or an external light source primarily designed to illuminate the sign. The illumination is “external” when the light source is separate from the sign surface and is directed to shine upon the sign and “internal” when the light source is contained within the sign, but does not include signs where the text or image is composed of dot matrix or LEDs. External illumination is “direct” when the source of light is directly seen by the public, such as a floodlight, and “indirect” when the source of light is not directly seen by the public, such as cove lighting.

“Incidental Sign” means a sign that is not legible to a person of ordinary eyesight with vision adequate to pass a state driver’s license exam standing at ground level at a location on the public right of way or on other private property.

“Indirect” means, when describing the illumination of a sign, external illumination from a source located away from the sign, which lights the sign, but which is itself not visible to persons viewing the sign from any street, sidewalk or adjacent property.

“Integral Sign” means a sign that is embedded, extruded or carved into the material of a building façade. A sign made of bronze, brushed stainless steel or aluminum, or similar noncombustible material attached to the building façade and projecting no more than two inches from a building.

“Interior sign” means a sign erected and maintained inside of a building, including, but not limited to, a sign attached to or painted on the inside of windows. This definition does not include text, pictures, graphics, or similar representations in display windows.

“Lawn Sign” means a temporary freestanding sign made of lightweight materials such as cardboard or vinyl that is supported by a frame, pole or other structure placed directly in or upon the ground without other support or anchor.

“LED” means a semiconductor diode that converts applied voltage to light and is used in digital displays.

“Lot” means a single unit of land that is created by a subdivision of land.

“Maintenance” means normal care or servicing needed to keep a sign functional or perpetuate its use, such as cleaning, replacing or repairing a part made unusable by ordinary wear, and changing light bulbs.

“Marquee” means a permanent roofed structure attached to or supported by a building.

“Menu board” means a sign placed at the beginning of a drive-up service lane of a food service establishment that includes a two-way speaker system for taking food orders.

“Monument sign” means a freestanding sign that is placed on a solid base that extends a minimum of 12 inches above the ground and extends at least 75 percent of the length and width of the sign. The above ground portion of the base is considered part of the total allowable height of a monument sign.

“Multiple-Driveway Sign” means a sign at the exit or entrance of a premise that has two or more driveways.

“Name plate” means a permanent wall sign located on the front facade of a residential structure.

“Noncommercial Speech” means any message that is not commercial speech, which includes but is not limited to, messages concerning political, religious, social, ideological, public service and informational topics.

“Numeric information sign” means a sign only displaying current numeric measurements such as time, date, temperature, or stock indices.

“Original Art Display” A hand-painted work of visual art that is either affixed to or painted directly on the exterior wall of a structure with the permission of the property owner. An original art display does not include: mechanically produced or computer-generated prints or images, including but not limited to digitally printed vinyl; electrical or mechanical components; or changing image art display.

“Owner” means the person owning title to real property on which a sign is located, or the contract purchaser of the real property as shown on the last available complete assessment roll in the office of county assessor. “Owner” also includes the owner of a sign who has a continuing lease of the real property on which the sign is located.

“Pennant” means any flag.

“Person” means every person, firm, partnership, association, or corporation.

“Planned unit development” means a tract or tracts of land developed as a planned unit development under city zoning / development ordinances.

“Pole sign” means a sign that is a freestanding sign connected to the ground by one or more supports with the lower edge of the sign separated vertically from the ground by a distance of nine feet or greater as measured from grade.

“Portable sign” means a sign which is not affixed to a building or other structure, or the ground in a permanent manner and is designed to be moved from place to place.

“Principal use” means a nonresidential use of property by an owner or lessee. Multiple principal uses may be located on a lot or development.

“Prior lawful nonconforming sign” means a sign whose location, dimensions or other physical characteristics do not conform to the standards of this ordinance but which was legally constructed or placed in its current location prior to the enactment of this ordinance or its amendment that made it nonconforming.

“Projecting sign” means a sign, other than a wall sign, that projects from, and is supported by or attached to, a roof or wall of a building or structure.

“Public right of way” means travel area dedicated, deeded or under control of a public agency, including but not limited to, highways, public streets, bike paths, alleys and sidewalks.

“Public sign” means a sign erected, constructed, or placed within the public right of way or on public property by or with the approval of the governmental agency having authority over, control of, or ownership of the right of way or public property.

“Repair” means mending or replacing broken or worn parts with comparable materials.

“Roof elevation area” means the area of a single plane of a roof, measured in square feet and calculated by multiplying the difference between the height of the ridge and the height of the eave by the distance between opposing rakes.

“Roof line” means the top edge of a roof or a building parapet, whichever is higher, excluding any cupolas, chimneys or other minor projections.

“Roof sign” means a sign erected upon, against, or over the roof of any building or structure.

“Rope Light” means a light that has holiday lights or mini lights inside of a PVC tube.

“Seasonal decorations” means every type of decoration displayed on a seasonal basis.

“Setback” means the horizontal distance from the property line to the sign, measured at the closest points of the sign to the property line.

“Sign” means a display, illustration, structure or device that has a visual display visible from a public right of way and designed to identify, announce, direct, or inform. The scope of the term

“sign” does not depend on the content of the message or image being conveyed.

“Sign area” means the area of the sign measured within lines drawn between the outermost points of a sign, but excluding essential sign structures, foundations, or supports.

“Sign band” means a continuous horizontal band located on a facade where there are no doors, windows or other architectural features.

“Sign copy” means the message or image conveyed by a sign.

“Sign face” means the sum of the surfaces of a sign face as seen from one plane or elevation included within the outer dimensions of the sign board, frame or cabinet.

“Sign height” means the average level of the grade below the sign to the topmost point of the sign including the supporting sign structure, foundations, and supports.

“Site” means the area, tract, parcel, or lot of land owned by or under the lawful control of an owner. Abutting platted lots under the same ownership shall be considered one site.

“Street frontage” means the length or width of a site, measured along a line separating the site from a street or public right of way.

“String Light” means a lighting fixture that is composed of electrical wiring encased in plastic with sockets for bulb placement.

“Structure” means that which is built or constructed. An edifice or building of any kind or any piece of work artificially built up or composed of parts joined together in some definite manner and which requires location on the ground or which is attached to something having a location on the ground.

“Subdivision” means a site with four or more lots.

“Supporting structure” means a structure specifically intended for supporting or containing a sign.

“Suspended sign” means a sign suspended from the underside of a canopy, awning, eve, or marquee.

“Temporary business” means a temporary business as defined by the city of [City] Municipal Code.

“Temporary sign” means a sign that is attached to a building, structure, vegetation, or the ground for what is expected to be a transitory or temporary period. Temporary signs include, but are not limited to, A-frames, banners, flags, pennants, balloons, blimps, streamers, lawn signs and portable signs.

“Transportation system plan (TSP)” means that portion of the city of [City] Comprehensive Plan that implements the State of Oregon Transportation Planning Rule OAR 660-012.

“Tri-vision sign” means a sign that contains display surfaces composed of a series of three-sided rotating slates arranged side by side, either horizontally or vertically, that are rotated by an electro-mechanical process, capable of displaying a total of no more than three separate and distinct messages, one message at a time, provided that the rotation from one message to another message is no more frequent than every eight seconds and the actual rotation process is accomplished in four seconds or less.

“Unlawful Sign” means a sign that does not conform to the provisions of this Code and is not a nonconforming sign.

“Utility Sign” means a sign constructed or placed by a public utility on or adjacent to a pole, pipe, or distribution facility of the utility and within the public right of way or utility easement.

“Vehicle sign” means a sign placed in or attached to the motor vehicle, trailer, railroad car, or light rail car that is used for either personal purpose or is regularly used for purposes other than the display of signs.

“Video sign” means a sign providing information in both a horizontal and vertical format (as opposed to linear), through use of pixel and sub-pixel technology having the capacity to create continuously changing sign copy in a full spectrum of colors and light intensities.

“Vision clearance area” means a triangular area on a lot at the intersection of two streets or a street and a railroad, alley, or driveway as defined and measured in [City] Zoning Ordinance.

“Wall sign” means a sign that is painted on a wall of a building, or a sign attached to the wall of a building and extending no more than 12 inches from a wall, or attached to or erected against a roof with a slope not more than 20 degrees from vertical, with the exposed face of the sign in a plane that is vertical or parallel to the plane of that roof, and which does not project more than 18 inches from the wall or roof. Window signs that are permanently attached to the outside of a window are wall signs.

“Window sign” means a sign attached to or painted on a window, or displayed inside the building within six inches of a window or building opening so that it is viewable from the outside of the building.

“Zoning / development ordinance” means [City’s name for its zoning / development ordinance or community development code].

XX.XX.020 General requirements.

- A. Except as provided in Section XX.XX.025 of this chapter, no person shall erect, construct, enlarge, alter, repair, move, improve, remove, convert, demolish, equip, use or maintain any sign, or cause or permit the same to be done, contrary to or in violation of any of the provisions of the [City] Sign Code.
- B. Except for government signs, railroad, or utility signs or for signs required by state or federal laws or regulations to be of a certain color or size, signs shall be designed to be compatible with other nearby signs, other elements of street and site furniture and with adjacent structures. Compatibility shall be determined by the relationships of the elements of form, proportion, scale, color, materials, surface treatment, overall sign size and the size and style of lettering.

Comment: This general requirement for sign compatibility was one of the sections challenged in the G.K. Travel v. City of Lake Oswego case. The City prevailed based on the strength of its procedures for administering this section. Thus, if a jurisdiction wishes a heightened level of aesthetic compatibility, the drafter is urged to review the procedures discussed in G.K. Travel as guidance in assuring that the requirement is constitutionally administered.

- C. Except as provided in Section XX.XX.040 of this chapter, no person shall erect, construct or alter a sign, or permit the same to be done, unless a sign or billboard permit has been issued by the city. A sign or billboard permit for the construction and continued use of a sign is subject to the terms and conditions stated in the permit and to the [City] Sign Code.
- D. An application for sign permit approval is subject to the procedures set forth in Section XX.XX.125 of this chapter. An application for billboard permit approval is subject to the additional requirements set out in Section XX.XX.075 of this chapter.
- E. No owner shall erect or construct a sign on a site that contains unlawful signs.
- F. The [City] Sign Code shall not be construed to permit the erection or maintenance of any sign at any place or in any manner unlawful under any other city code provision or other applicable law. In any case where a part of the [City] Sign Code conflicts with a provision of any zoning/development, building, fire, safety or health ordinance or code, the provision which establishes a stricter standard for the protection of the public health and safety shall prevail.
- G. Subject to the landowner's consent, noncommercial speech of any type may be substituted for any duly permitted or allowed commercial speech; provided, that the sign structure or mounting device is legal without consideration of message content. Such substitution of message may be made without any additional approval or permitting. This provision prevails over any provision to the contrary in this ordinance. The purpose of this provision is to prevent any inadvertent favoring of

commercial speech over noncommercial speech, or favoring of any particular noncommercial message over any other noncommercial message. This provision does not create a right to increase the total amount of signage on a lot or parcel, nor does it affect the requirement that a sign structure or mounting device be properly permitted.

- H. The [City] Sign Code is not intended to, and does not restrict speech on the basis of its content, viewpoint or message. Any classification of signs in this chapter that permits speech by reason of the type of sign, identity of the sign user or otherwise, shall permit any type of speech on the sign. No part of this chapter shall be construed to favor commercial speech over noncommercial speech. To the extent any provision of this chapter is ambiguous, the term shall be interpreted to not regulate on the basis of speech content, and the interpretation resulting in the least restriction on the content of the sign message shall prevail.
- I. If any section, subsection, paragraph, sentence, clause or phrase of the [City] Sign Code is declared invalid for any reason by a court having jurisdiction under state or federal law, the remaining portions of this chapter shall remain in full force and effect.

XX.XX.025 Exempt signs.

Except for signs prohibited by this chapter, the following signs are exempt from the provisions of the [City] Sign Code:

- A. Incidental signs.
- B. Grave markers.
- C. Original art displays that do not constitute commercial speech.
- D. Seasonal decorations, rope lights, string lights, holiday lights or mini-lights.
- E. [*Additional exempt signs desired by jurisdiction.*]

XX.XX.030 Prohibited signs.

Except for nonconforming signs, the following signs are unlawful and are nuisances:

- A. Abandoned signs;
- B. Beacon signs, except those associated with emergencies or aircraft facilities;
- C. Flying signs, such as blimps or kites, designed to be kept aloft by mechanical, wind, chemical or hot air means that are attached to the property, ground or other

permanent structure;

- D. Inflatable signs that are attached to the property, ground or other permanent structure, including but not limited to balloons;
- E. Signs and components and elements of faces of signs that move, shimmer, or contain reflective devices;
- F. Signs which emit any odor, noise or visible matter other than light;
- G. Commercial speech affixed to any transmission facility;
- H. A vehicle, including a trailer, used as a sign or as the base for a sign where the primary purpose of the vehicle in that location is its use as a sign;
- I. Billboards, except as permitted by Section XX.XX.075 of this chapter;
- J. Video signs;
- K. Any sign constructed, maintained or altered in a manner not in compliance with the [City] Sign Code;
- L. Any nonpublic sign constructed or maintained which, by reason of its size, location, movement, coloring or manner of illumination may be confused with or construed as a traffic control device or which hides from view any traffic control device;
- M. Any sign (other than a government sign) constructed in such a manner or at such a location that it will obstruct access to any fire escape or other means of ingress or egress from a building or an exit corridor, exit hallway or exit doorway. No sign or supporting structure shall cover, wholly or partially, any window or doorway in any manner that it will substantially limit access to the building in case of fire;
- N. Any sign located in a manner which could impede traffic on any street, alley, sidewalk, bikeway or other pedestrian or vehicular travel way;
- O. Any sign equipped with moving, rotating or otherwise animated parts, except for tri-vision signs permitted under Section XX.XX.075 of this chapter and athletic scoreboards permitted under Section XX.XX.040;
- P. Any sign that is wholly or partially illuminated by a flashing or intermittent light, lights, lamps, bulbs, or tubes. Rotary beacon lights, zip lights, strobe lights, or similar devices shall not be erected or maintained, or attached to or incorporated in any sign;

- Q. Any sign (other than a government sign) within the vision clearance area provisions contained in the zoning/development ordinance;
- R. Any sign attached to a tree or a plant, a fence or a utility pole, except as otherwise allowed or required by the [City] Sign Code or other chapters of the City Code;
- S. Any sign within or over any public right of way, or located on private property less than two feet from any area subject to vehicular travel, except for:
 - 1. Public signs, (includes banners over the public right of way, with the approval of the controlling jurisdiction).
 - 2. Temporary signs specifically allowed within the public right of way under Section XX.XX.045 of this chapter.
 - 3. Temporary signs, including banners, pennants, and wind signs, except as authorized by Section XX.XX.040 or XX.XX.045 of this chapter.
 - 4. Unlawful signs.
 - 5. Any sign which is judicially determined to be a public nuisance.

XX.XX.035 Prior Lawful Nonconforming Signs.

- A. Nonconforming signs may continue in use, subject to the restrictions in this subsection:
 - 1. **[OPTION #1]** Removal Required for Specific Nonconforming Signs. All nonconforming **[type of sign]** signs shall be brought into compliance with **[applicable code section for the zone]** by ___, 20[XX].
 - 2. **[OPTION #2]** Removal Generally Required for Nonconforming Signs Following Amortization Period. Any sign constructed made nonconforming by a provision of the sign code:
 - [Option 2a]** may be maintained for a period ending no later than **[three][five]** years from the date such sign becomes nonconforming.
 - [Option 2b]**. may be maintained for a reasonable period of time to amortize the investment therein. The amortization period shall be determined as follows:
 - a. Except as provided in paragraphs (b) and (c) of this subsection, every nonconforming sign shall be removed in accordance with the following amortization schedule:

Value	Maximum Period of Time Sign May Be Maintained
Less than \$500	1-1/2 years
\$500 to \$1,000	2 years
For each additional \$1,000 increment	One additional six-month period
Maximum period regardless of value	5 years

- b. The value of any nonconforming sign shall be determined by the following formula:

$$V = C - (10\% C) Y$$

V = Value of the sign for amortization purposes

C = Original cost of the sign, including the cost of construction and installation

Y = Number of years the sign has been standing as of the effective date of the ordinance codified in this title

- c. The amortization period shall begin on the date of mailing by the **[City Manager]** of notice to the owner of the property on which the sign is located (as determined from the most recent tax assessor's roll), of the fact that the sign is nonconforming and subject to amortization. The notice shall include a statement of the owner's right to seek an extension of the amortization period under subsection (3) of this section.

Comment: Alternatively, the jurisdiction may wish to consider the amortization period automatically starting upon the date the sign becomes nonconforming, with the one-year opportunity to seek an extension to start then. This may depend upon how extensive changes in the sign code are publicized in the jurisdiction, and the degree of responsibility it wishes to place upon the sign owner.

- d. Notwithstanding any other provision in this paragraph, any nonconforming sign that has been fully depreciated for federal or state income tax purposes shall be removed or modified to comply with the provisions of the sign code within one year of the date the sign became nonconforming.

3. Extension of Amortization Period. If the amortization period established by the above provision of this section creates an exceptional hardship for the sign owner, the owner may make an application for an extension of the amortization period, provided the application is submitted before the expiration of such amortization

period. For purposes of this subsection, “owner” includes lessee.

- a. Application. An application shall be submitted to the **[City Manager]** and shall be accompanied by a fee as may be set by resolution adopted by the City Council. The application shall contain the name and address of the sign owner, the land owner, the type, location and size of sign, the date the sign was erected, the height (including supports) of the sign, the cost of construction, and the length of time extension is requested; and shall be accompanied by a detailed statement of reasons an extension is sought, and why the amortization period constitutes an exceptional hardship.
- b. Procedures. Applications for extension of an amortization period shall be heard by the **[hearing body]**, which shall determine whether the application satisfies the criteria set forth in subsection (A)(3) of this section. The **[hearing body]** may grant or deny the extension, and impose such conditions as may be necessary to minimize the adverse effects of such extension upon surrounding properties. In granting an extension, the **[hearing body]** shall determine the length of the time for the extension. The findings and the basis for the **[hearing body]**’s decision shall be transmitted to the applicant in writing.
- c. Criteria. In considering an application for an extension of the amortization period for a nonconforming sign, the following criteria shall be applied:
 - i. The original cost of the sign;
 - ii. The date the sign was constructed and located on the site;
 - iii. The degree of deviation from the sign regulations;
 - iv. Whether unusual circumstances concerning the sign’s size, height, location or nature are present;
 - v. The nature of the exceptional hardship, and whether allowing an extension in light of the hardship would be inconsistent with the intent of sign amortization;
 - vi. The effect of the nonconforming sign on the use, value, and enjoyment of surrounding and neighboring properties;
 - vii. The least amount of additional time required, if any, for the applicant to amortize any unreasonable economic loss, over and above the amortization period already permitted under this section; and

- viii. Proof that the sign has not been fully depreciated for federal income tax purposes shall be required except in extraordinary circumstances where such proof is deemed inapplicable.

4. General Requirements for Nonconforming Signs.

a. A nonconforming sign shall not be:

- i. Modified, unless the modification brings the sign into compliance with this Chapter. A change of copy is allowed, except that any change in a wall sign which is painted on a structure shall comply with **[applicable code section for the zone]**.
- ii. Expanded.
- iii. Relocated.

b. A nonconforming sign may undergo normal maintenance with the following exceptions:

- i. “Normal maintenance” excludes major structure repairs designed to extend the useful life of the nonconforming sign.
- ii. **[Option #1]** If a nonconforming sign is damaged by wind, fire, neglect or by any other cause, and such damage exceeds 60 percent of its replacement value, the non-conforming sign shall be removed.
- iii. **[Option #2]** When any proposed change, repair, or maintenance would constitute an expense of more than **[50][25]** percent of the lesser of the original value or replacement value of the sign, the non-conforming sign shall be removed.

c. Upon change of use of a business or premise, a nonconforming sign shall be brought into compliance with **[applicable code section for the zone]** within 180 days.

d. Abandoned signs shall not be permitted as nonconforming signs.

B. Nothing in this section shall be deemed to prevent the maintenance of any sign, or regular manual changes of sign copy on a sign.

C. Continuation of Prior Lawful Nonconforming Sign as Public Nuisance; Removal and Abatement.

- 1. The continuation of any nonconforming sign beyond the time period(s) set forth in

Subsection A of this Section is hereby declared to be a public nuisance, which may be abated as provided by this section.

2. Any nonconforming sign that remains in place after the expiration of the amortization period, or any extension thereof, shall be removed within 30 days after a written notice for removal has been posted on the property upon which the sign is located, and a copy sent by certified mail, postage prepaid, to the sign owner and land owner, if different. Such notice shall state the particulars of the violation and require removal of the sign upon or before a date specified in the notice, but not less than 30 days after such posting and mailing, and that written objections to such removal may be filed with the **[City Manager]** on or before such date. If the nonconforming sign is not removed on or before the date specified in the notice, and if no written objections to such removal are filed, the **[City Manager]** may cause the removal thereof at the expense of the owner of the real property upon which such sign is located.
3. Upon receipt of timely filing of objections, the nonconforming sign shall remain in place. Hearing upon the objections shall be held before the City Council. Notice of the time, date and place of the hearing shall be personally delivered, or mailed by certified mail, postage prepaid, to the person filing such objections at the address provided in the objections, at least ten days prior to the hearing.
4. Any nonconforming sign ordered removed by the City Council shall be removed within 30 days after notice of the removal order has been mailed to such objector and if not removed within such time, the **[City Manager]** shall cause the removal to be made at the expense of the owner of the real property upon which such sign is located.

XX.XX.040 Exemptions from requirement for permit.

The following signs are allowed in all sign districts without a permit. Use of these signs does not affect the amount or type of signage otherwise allowed by this chapter. The painting, repainting, cleaning, maintenance and repair of an existing sign shall not require a permit, unless a substantial structural alteration is made. The changing of a sign copy or message shall not require a permit. All signs listed in this section are subject to all other applicable requirements of the **[City]** Sign Code.

- A. Integral signs;
- B. Government signs;
- C. One indirectly illuminated or nonilluminated sign not exceeding one and one-half square feet in an area placed on any non-multifamily residential lot. This type of sign is typically used as a name plate;

- D. Flags;
- E. Vehicle signs that are not prohibited signs under XX.XX.030;
- F. Signs displayed upon a bus or light rail vehicle owned by a public transit district;
- G. Historical signs or historical or landmark markers;
- H. Handheld signs;
- I. A sign up to six square feet constructed or placed within a parking lot, for each [XX] square feet of parking area. These signs are typically used to direct traffic and parking;
- J. A sign within the public right of way that is erected by a governmental agency, utility or contractor doing authorized work within the right of way;
- K. A sign that does not exceed eight square feet in area and six feet in height, and is erected on property where there is a danger to the public or to which public access is prohibited;
- L. Nonilluminated interior signs in nonresidential sign districts designed primarily to be viewed from a sidewalk or street, provided the sign does not obscure more than 25 percent of any individual window;
- M. Illuminated interior signs in nonresidential sign districts designed primarily to be viewed from a sidewalk or street, provided the sign face is less than four square feet in area;
- N. One suspended sign for each principal use erected on property which is not considered public right of way, under an attached first floor awning or canopy upon a building with direct exterior pedestrian access, provided the sign does not exceed six square feet in area and has a minimum of eight feet of clearance;
- O. An exterior sign erected next to an entrance, exit, rest room, office door, or telephone, provided the sign is no more than four square feet in area. This type of sign is typically used to identify and locate a property feature;
- P. Signs located within a sports stadium or athletic field, or other outdoor assembly area which are intended for viewing by persons within the facility. The signs shall be placed so as to be oriented towards the interior of the field and the viewing stands;
- Q. Signs incorporated into vending machines or gasoline pumps;

R. Temporary signs as allowed under Section XX.XX.045 of this chapter;

S. Utility signs;

Comment: A jurisdiction may wish to establish limitations for utility signs, in which case utility signs should be addressed in a separate section.

T. Signs for hospital or emergency services, and railroad signs.

XX.XX.045 Temporary signs.

Comment: The listing of types and number of temporary signage permitted throughout the jurisdiction is illustrative. See other jurisdictions' sign codes to compare the type and number of temporary signs permitted throughout a particular city.

- A. Temporary signs may be erected and maintained in the city only in compliance with the regulations in this chapter, and with the following specific provisions:
1. Except in connection with a community event, no temporary sign shall be internally illuminated or be illuminated by an external light source primarily intended for the illumination of the temporary sign.
 2. A temporary sign shall be attached to the site or constructed in a manner that both prevents the sign from being easily removed by unauthorized persons or blown from its location and allows for the easy removal of the sign by authorized persons.
 3. Except as provided in this code, temporary signs shall not be attached to trees, shrubbery, utility poles or traffic control signs or devices.
 4. No temporary sign shall be erected or maintained which, by reason of its size, location or construction constitutes a hazard to the public.
- B. In any residential sign district, the following temporary signs shall be allowed on a lot without issuance of a permit and shall not affect the amount or type of signage otherwise allowed by this chapter. This signage shall not be restricted by content. Signage shall be allowed for each lot as follows:

Comment: Note that this sign code authorizes different types or numbers of temporary signs based on the type of sign district where the sign is located. If sign districts are not utilized, then the drafter should revise this section accordingly to reflect the jurisdiction's wishes. See XX.XX.050 Sign Districts.

1. Signs not exceeding six square feet in area or four feet in height during the period from 120 days before a public election or the time the election is called, whichever is earlier, to five days after the public election.
2. One temporary sign not exceeding six square feet in area and four feet in height which is erected for a maximum of eight days in any calendar month and is removed by sunset on any day it is erected.
3. A sign not exceeding six square feet in area and five feet in height during the time of sale, lease or rental of **[the lot] [a dwelling]** provided that the sign is removed within 15 days of the sale, lease or rental of the **[lot] [dwelling]**.

Comment: Some jurisdictions use the term “property”, but the League recommends a more specific, and defined term, as to whether the event is related to the sale of a dwelling or to the underlying lot. Multi-family dwellings located on a single lot, i.e., apartments, condominiums, may result in temporary signs that seem more akin to permanent signs if the multi-family dwelling structure has a re-occurring turnover of units.

4. A sign not exceeding six square feet in area during the time of construction or remodeling of the property, provided the sign is removed within seven days of the completion of any construction or remodeling. An additional sign of the same size may be erected if the property borders a second street and the signs are not visible simultaneously. On lots of more than two acres, the sign area may be increased to 32 square feet. In no case shall the sign or signs be erected for more than 12 months.
 5. On property which has received subdivision or development approval from the city, from that approval until issuance of a building permit for the last lot to be sold or completion of the development project, one temporary sign not exceeding 32 square feet in area and eight feet in height on properties less than four acres in size or two temporary signs not exceeding 64 square feet in area each and eight feet in height on properties greater than four acres in size.
- C. In any commercial sign district or industrial sign district, the following temporary signs shall be allowed on a lot without issuance of a permit and shall not affect the amount or type of signage otherwise allowed by this chapter. This signage shall not be restricted by content. Signage shall be allowed for each lot as follows:
1. Signs not exceeding four square feet in area and five feet in height, during the period from 120 days before a public election or the time the election is called, whichever is earlier, to five days after the public election.
 2. A sign not exceeding 32 square feet in area and eight feet in height during the time of sale, lease or rental of the property provided that the sign is placed on the property for sale, lease, or rental and removed within 15 days of the sale, lease or

rental of the property, or a sign not exceeding 32 square feet in area and eight feet in height during the time of construction and remodeling of the property, provided the sign is placed on the property where construction and remodeling is taking place and removed within seven days of the completion of any construction or remodeling. An additional sign of the same size may be erected if the property borders a second street and the signs are not visible simultaneously. In no case shall the sign or signs be erected for more than 12 months.

3. A sign not exceeding 32 square feet in an area during the period of charitable fundraising event being conducted on the property where the sign is erected. This sign shall not be placed more than seven days prior to the event and must be removed within two days following the event.

D. No temporary signs or banners shall be allowed in the public right of way or on public property, except for those listed in this subsection.

1. The following temporary signs shall be permitted in the right of way without issuance of a permit and shall not affect the amount or type of signage otherwise allowed by this chapter. No temporary sign in the right of way shall interrupt the normal flow of vehicle, pedestrian or bicycle traffic and shall provide a minimum of five feet of clear passage for pedestrians on a sidewalk where a sidewalk exists. No temporary sign shall extend into a vision clearance area. Temporary signs allowed in the right of way shall include:
 - a. Government signs;
 - b. Signs on public sidewalks in all **[list applicable]** districts and adjacent to commercial uses in the **[listed specific]** districts which comply with the following standards:
 - i. Any temporary sign is placed on the sidewalk within the first three feet behind the curb, and
 - ii. Any temporary sign is present only during the business hours of the responsible enterprise, and
 - iii. Any temporary sign placed elsewhere than directly adjacent to the primary use shall be placed only with the written consent of the property owner of the adjacent property. No more than two temporary signs shall be placed in the public right of way adjacent to any property frontage on a single street;
 - c. Portable signs limited to a maximum of six square feet in area and three feet in height, displayed only on weekends and holidays, placed at street intersections in relative close proximity to a property for sale or lease

during the time of that display. One single sign for each property or development shall be permitted at each intersection and shall be positioned as to be no closer than two feet from areas subject to vehicular travel;

- d. Bench signs located at mass transit stops so long as the bench sign copy does not exceed 15 square feet and the bench sign is approved by the owner;
 - e. Signs attached to mass transit shelters which are approved by the mass transit agency and the owner.
2. Temporary banners or seasonal decorations which extend over a roadway or are attached to utility or streetlight poles shall be permitted in the right of way upon issuance of a permit in accordance with the procedures set out in Sections XX.XX.125 and XX.XX.130 of this chapter and shall comply with the following standards:
- a. Banners or decorations which extend over a roadway shall not exceed 60 square feet in area. Banners which are attached to a single utility or streetlight pole shall not exceed 12 square feet in area.
 - b. Temporary banners or decorations shall be permitted only if the applicant is conducting an event or activity in the city that has been identified as a community event by the city council or for purposes of identifying a geographic area or district of the city. Applications for geographic identification banners shall be submitted by an organized neighborhood association, or shall be accompanied by a petition indicating the consent of at least 51 percent of the property owners or retail establishments in the geographic area delineated on the banner application.
 - c. Applicants requesting permits for temporary banners or decorations in city right of way shall obtain all permits and approvals as outlined in Chapter XX.XX.045(D) of this Code prior to submittal of an application for a sign permit. Applicants requesting temporary banners placed over rights of way controlled by other agencies other than the city shall obtain written consent from the appropriate agency regarding the proposed banner(s) prior to submittal of an application for a sign permit. The consent shall identify any restrictions desired by the owner of the right of way.
 - d. Except for a banner(s) identifying a geographic area or district of the city, banner(s) shall be removed within two days of the applicant's event or activity giving rise to the permit.

XX.XX.050 Sign districts—General.

Comment: If the jurisdiction does not view the sign code as a land use regulation, the drafter is

cautioned regarding the sign districts being co-terminus with, and using the same designations as, the zoning districts for the jurisdiction. Although not necessarily determinative, the more similarities the sign code has to the jurisdiction's land use scheme, the more likely it may be thought of as a land use regulation, by the public and perhaps by the courts.

- A. The following sign districts are created and applied to designated land. No permit shall be issued for any sign unless specifically allowed as an allowed sign under the terms of the applicable sign district or otherwise allowed as a nonconforming sign under Section XX.XX.035 or exempted under Section XX.XX.040 of this chapter. Any particular limitation in a sign district regulation shall not be construed to exclude the applicability of other restrictions imposed under this chapter.

- B. The sign districts shall be as follows:
 - 1. The residential sign district includes all land within the **[list sign/zone]** districts.
 - 2. The commercial sign district includes all land within the **[list sign/zone]** districts.
 - 3. The industrial sign district includes all land within the **[list sign/zone]** zoning districts.
 - 4. **[List any additional sign/zone districts].**
 - 5. **[List any additional Overlay Districts/corridors].**

- C. Property within a newly designated **[sign/zone]** district shall be governed by the provisions of the sign code applicable to the new **[sign/zone]** district upon the effective date of the ordinance amending the **[sign/zone]** map. Completed applications for sign permits made before the effective date of the **[sign district/zone]** change will be considered under the provisions of the **[City]** Sign Code applicable to the **[sign/zone]** district existing at the time the application was completed. All signs which are not in compliance with the provisions of the **[City]** Sign Code applicable to the newly established **[sign/zone]** district shall be considered nonconforming signs.

XX.XX.055 Residential sign district.

Comment: In determining signage for a specific area or zone/sign district, the drafter is cautioned to fully consider the uses in the zone/district, the types of signs that should be permitted, sign height, illumination, changeable copy, compatibility, etc. The specific provisions below reflect the policy choices by the City of Hillsboro, and are shown for illustrative purposes.

In addition to the temporary and permanent signage allowed without permits, the following signage is allowed subject to the requirements of this chapter:

- A. Permitted Sign Types, Number and Area. Signs within the residential sign district are

limited as follows and require issuance of permits under Section XX.XX.130 of this chapter.

Comment: In referencing specific types of dwellings within the districts, the drafter is cautioned to refer to the jurisdiction's zoning ordinance, and to either similarly define them in the sign code or at least by reference to the zoning/development code.

A different formatting option is to list the sign/zone districts, and then list under each zone the types of signs permitted within the sign/zone districts – more text but perhaps more user-friendly.

1. Monument and Ground-Mounted Signs.

- a. In multifamily developments, one double-faced monument sign, or not more than two single-faced monument signs on either side of a vehicular entrance shall be permitted on the primary street frontage. Sign area shall not exceed 16 square feet for each sign face. Where a complex has multiple street frontages, this signage may be permitted on each building frontage that abuts a TSP designated arterial or collector street.
- b. In subdivisions, not more than two single-faced monument signs for a subdivision or planned unit development having 20 or more lots may be permitted on either side of a public right of way or private street tract entrance. Sign area shall not exceed 16 square feet for each sign face.
- c. For churches, schools, public/semipublic facilities, and privately-owned community centers, one single- or double-faced monument sign shall be permitted for each such facility. Where such a facility has multiple street frontages, this signage may be permitted on each frontage. Sign area shall not exceed 16 square feet for each sign face.
- d. For commercial and office uses in **[name of district]** Commercial districts, one single- or double-faced monument sign shall be permitted on the primary frontage of the development. In lieu of one monument sign, one single- or double-faced ground-mounted sign shall be permitted on the primary frontage of developments which contain five or more principal uses in one structure. Where a development has multiple street frontages, this signage may be permitted on each building frontage that abuts an arterial or collector street. Sign area shall not exceed 30 square feet for each sign face.

2. Bulletin Boards.

- a. For schools, churches, public and semipublic facilities, and privately owned community centers, one single- or double-faced bulletin board may be incorporated into an approved monument sign. Sign area for a bulletin board shall not exceed 24 square feet for each sign face.

- b. For commercial and office uses in **[name of district]** Commercial districts, one single- or double-faced bulletin board per site may be incorporated into an approved monument or ground-mounted sign. Sign area of the bulletin board portion of the sign shall not exceed 65 percent of the total sign face.

3. Wall Signs.

- a. For commercial uses permitted in **[name of district]** districts, one wall sign for each tenant occupancy shall be permitted. Sign area for all wall signs shall not exceed eight percent of the building elevation area, with a maximum individual sign face area of 50 square feet on primary frontages. Sign area for all wall signs shall not exceed six percent of the building elevation area on secondary frontages, with a maximum individual sign face area of 25 square feet.
- b. For churches, schools, and public/semipublic facilities, one wall sign for each building frontage shall be permitted. Sign area for all wall signs shall not exceed eight percent of the building elevation area with a maximum individual sign face area of 50 square feet on primary frontages, and six percent of the building elevation area on secondary frontages, with a maximum sign face area of 25 square feet.
- c. For commercial and office uses in **[name of district]** Commercial districts, total sign face area for all primary building-mounted wall signs shall not exceed 12 percent of the building elevation area with a maximum individual sign face area of 100 square feet. Where the use has multiple frontages, the signage on secondary frontages shall not exceed eight percent of the building elevation area with a maximum sign face area of 50 square feet. No more than two wall signs shall be permitted on the primary building frontage. Only one wall sign shall be permitted on the secondary frontage.

4. Awning Signs.

- a. For commercial uses permitted in **[name of district]** districts, one awning sign for each building frontage shall be permitted. Total sign area including wall signs shall not exceed 12 percent of the building elevation area, with a maximum sign face area of 50 square feet on primary frontages, and eight percent of the building elevation area on secondary frontages, with a maximum sign face area of 25 square feet.
- b. For churches, schools, and public/semipublic facilities, one awning sign for each building frontage shall be permitted. Total sign area including wall signs shall not exceed 12 percent of the building elevation area, with a maximum sign face area of 50 square feet on primary frontages, and eight percent of the building elevation area on secondary frontages, with a maximum sign face

area of 25 square feet.

- c. For commercial and office uses in **[name of district]** Commercial districts, total sign face area for primary building-mounted wall signs and awning signs shall not exceed 12 percent of the building elevation area with a maximum sign face area of 100 square feet. Where the use has multiple frontages, the signage on secondary frontages shall not exceed eight percent of the building elevation area, with a maximum sign face area of 50 square feet.
5. Projecting Signs. For upper floor businesses in the **[name of district]** district, two projecting signs for each street frontage shall be permitted for buildings having two or more floors and at least 50 feet of street frontage. Sign area for each sign shall not exceed six square feet.
 6. Suspended Signs. For each business in **[name of district]** districts, one suspended sign over public right of way shall be permitted under an attached first floor awning or canopy with direct exterior pedestrian access. Sign area shall not exceed six square feet.
 7. Banner Signs.
 - a. For multifamily residential developments, one banner sign shall be permitted for each development. The banner sign shall be limited to a display period of a maximum of 30 continuous days twice for each calendar year. Sign area shall not exceed 50 square feet.
 - b. For principal uses in **[name of district]** districts, one banner sign shall be permitted for each principal use. The banner sign shall be limited to a display period of a maximum of 30 continuous days twice during the calendar year. Sign area shall not exceed 50 square feet.
 - c. For temporary uses, one banner sign shall be permitted for each temporary use. The banner sign shall be allowed for the same duration as the temporary use. Maximum sign area shall not exceed 50 square feet.
- B. Maximum Sign Height. Monument signs shall be no more than six feet in height. Ground-mounted signs shall be no more than 12 feet in height.
- C. Illumination.
1. Except for monument signs in the **[name of district]** zoning district, athletic scoreboards, bulletin boards, and wall signs permitted in the **[name of district]** districts, any illumination of signs in the residential sign district shall be indirect.
 2. The illumination of signs within the residential sign district shall comply with the standards contained in Section XX.XX.125 of this chapter.

D. Historic Districts.

1. Within the **[name of historic district]** district, the design of all signs shall be historic in character, reflecting the type, style and materials of the historic period of the district. In evaluating the design of signs in the **[name of historic district]** district, the approving authority shall consider elements of form, proportion, scale, color, materials, surface treatment, overall sign size and the size and style of lettering. The planning department shall maintain an inventory of depictions of approved signs to offer guidance to applicants and the approving authority in the application of these standards. Plastic-faced signs, signs displaying flashing or intermittent lights or lights of changing degree of intensity, including bulletin boards, are prohibited in this district. The content of a sign message shall not be considered as a part of design review.
2. Within the **[name of historic district]** district, monument signs otherwise allowed by subsection (A)(1)(b) of this section are prohibited.
3. Within the **[name of historic district]** district, the design of a sign shall be evaluated in its relationship to the architectural style of the building on the site and signage on adjacent properties. To the extent feasible and without interfering with the communication need of the sign owner, the form, proportion, scale, color, materials, surface treatment, size, illumination, and size and style of lettering of a sign shall be harmonious with the building style and design, and signs of adjoining properties. The number of graphic elements on a sign shall be held to the minimum necessary to convey the sign message and shall be composed in proportion to the area of the sign face. Plastic-faced signs, signs displaying flashing or intermittent lights or lights of changing degree of intensity, including bulletin boards, are prohibited in this district. The content of a sign message shall not be considered as a part of design review.
4. When an applicant submits a determination by an architect or other design professional that the design standards of this section are met, it creates a rebuttable presumption that the criteria are satisfied. In order to overcome this presumption, and deny a sign permit for the failure to satisfy design criteria, the city must obtain a contrary opinion from an architect or other design professional that the criteria are not met and a recommendation of the design changes needed to obtain compliance with the standards.

XX.XX.060 Commercial sign district.

In addition to the temporary and permanent signage allowed without permits, the following signage is allowed subject to the requirements of this chapter:

Comment: In referencing specific types of uses within the districts, the drafter is cautioned to refer to the jurisdiction's zoning ordinance, and to either similarly define them in the sign code or at least by reference to the zoning/development code.

A. Permitted Sign Types, Number and Area. Signs within the commercial sign district are limited as follows and require the issuance of permits under Section XX.XX.130 of this chapter:

1. Monument or Ground-Mounted Signs.

- a. For principal uses, one single- or double-faced monument or ground-mounted sign shall be permitted for each lot along the primary street frontage. Where a use has multiple street frontages, this signage may be permitted along each building frontage that abuts an arterial or collector street. Sign area shall not exceed 40 square feet for each sign face.
- b. For places of worship, schools, and public/semipublic facilities, one single- or double-faced monument sign shall be permitted for each such facility. Where such a facility has multiple street frontages, this signage may be permitted on each frontage. Sign area shall not exceed 40 square feet for each sign face.
- c. Pole signs are prohibited within 300 feet of public right of way designated as a freeway or as light rail transit on the transportation system plan.
- d. Where up to five principal uses are contained in a building(s) with less than 30,000 gross square feet of building area, one monument or ground-mounted sign shall be permitted for each lot.
- e. Each parcel of property is also allowed:
 - i. For a lot that includes a drive-through window, one multiple driveway sign, no larger than ten square feet in surface area and 48 inches in height and located no more than six feet from a curb cut, and one further sign no larger than 30 square feet in surface area and facing the drive-through lane.
 - ii. For a lot (other than one including a drive-through window) that includes one or more lanes limited to one-way traffic, one additional multiple driveway sign, no larger than ten square feet in surface area and 48 inches in height and located no more than six feet from a curb cut.

2. Wall Signs. For a principal use, the total sign face area for all building-mounted wall signs, including multiple signs for multiple tenants, shall not exceed eight percent of the building elevation area on the primary frontage, with a maximum individual sign face area of 120 square feet. Where the use has multiple building frontages, the total signage area on secondary building frontages shall not exceed six percent of the building elevation area, with a maximum individual sign face area of 60 square feet. However, if the building elevation area on a frontage exceeds 5,000 square feet, the maximum individual sign area may increase to 199 square feet.

3. Awning Signs. For principal uses, the total sign face area for awning signs and wall signs shall not exceed 12 percent of the building elevation area on the primary frontage, with a maximum sign face area of 120 square feet. Where the use has multiple frontages, the signage on secondary building frontages shall not exceed eight percent of the building elevation area, with a maximum sign face area of 60 square feet.
4. Bulletin Boards.
 - a. Schools, places of worship and public and semipublic facilities, one single- or double-faced bulletin board may be incorporated into an approved monument or ground-mounted sign. Maximum sign area for a bulletin board shall not exceed 24 square feet for each sign face.
 - b. Theater Marquees. One single-faced bulletin board, or one double-faced bulletin board constructed so that the two faces connect at one end with an angle of 45 degrees or more, may be incorporated into a theater marquee. Maximum sign area for the bulletin board shall not exceed 12 percent of the building elevation area on the primary frontage, with a maximum sign face area of 120 square feet. The total combined area of theater marquee bulletin boards, awning signs and wall signs shall not exceed the maximum percentage of building elevation area permitted for the building elevation.
5. Banner Signs and Balloon Signs.
 - a. Principal Use. One banner sign or one balloon sign shall be permitted for each principal use and shall be limited to a display period of a maximum of 30 continuous days twice during the calendar year. Maximum sign area shall not exceed 50 square feet, as calculated pursuant to Section XX.XX.080(A) of this chapter.
 - b. Temporary Business. One banner sign or one balloon sign shall be permitted for a temporary business and shall be allowed for the same duration as the temporary business. Maximum sign area shall not exceed 50 square feet for a banner sign. Sign area for a balloon sign shall be calculated pursuant to Section XX.XX.080(A) of this chapter.
 - c. Balloon signs permitted in the commercial sign district shall be securely installed by a professional sign contractor.
6. Signs with a dynamic element.
 - a. Dynamic elements on signs are allowed in a Commercial Sign District subject to the prohibitions in Section XX.XX.030 and the following conditions in this section.

- b. Dynamic elements are allowed only on one sign per site.
- c. Dynamic elements are allowed only on monument signs and pole signs.
- d. Only one contiguous dynamic element is allowed on a sign face.
- e. A dynamic element may not change or move more often than once every **[20 minutes]** except one for which more frequent changes are necessary to correct information.
- f. The images and messages displayed must be static, and the transition from one static display to another must be instantaneous without any special effects.
- g. The dynamic element may not be illuminated to a degree of brightness than is greater than necessary for visibility. Signs found to be too bright shall be adjusted or removed as directed by the **[City Manager]**.
- h. Dynamic elements must be designed and equipped to freeze the element's display in one position if a malfunction occurs.
- i. Sign area of the dynamic portion of the sign shall not exceed 50 percent of the total sign face.
- j. For principal uses, one single- or double-faced electronic message sign per site may be incorporated into an approved monument or ground-mounted sign. Sign area of the electronic message portion of the sign shall not exceed 50 percent of the total sign face.
- k. For major or minor business complexes, one single- or double-faced electronic message sign per complex may be incorporated into a monument or ground-mounted sign. Sign area of the electronic message portion of the sign shall not exceed 50 percent of the total sign face.

7. Illuminated Interior Signs.

- a. For principal uses, one or more illuminated interior signs may be installed into the windows facing a public street or sidewalk. Sign area of individual illuminated interior signs shall not exceed four square feet; and the cumulative area of two or more illuminated interior signs installed in windows on the same building elevation shall not exceed 15 percent of the overall window area on that elevation.

- b. For major or minor business complexes, one or more illuminated interior signs may be installed into the windows facing a public street or sidewalk. Sign area of individual illuminated interior signs shall not exceed four square feet; and the cumulative area of two or more illuminated interior signs installed in windows on the same building elevation shall not exceed 15 percent of the overall window area on that elevation.
- 8. Projecting Signs. For principal uses, one or more projecting signs shall be permitted per use. Maximum sign area shall not exceed 20 square feet. Any premises with multiple street frontages may allocate the total allowable sign area among its projecting signs. Total sign area for wall and projecting signs shall not exceed 12 percent of the building elevation area on the primary frontage.
- 9. Roof Signs.
 - a. For a principal use, the **[City Manager]** may approve one roof sign, in lieu of other building-mounted signs, only upon finding that there are no other reasonable means of signing the business or use, due to extraordinary circumstances related to the physical location or structure of the building, distance from nearby streets, proximity of surrounding buildings or vegetation, or other factors over which the applicant has no control.
 - b. Approval of a roof sign shall be subject to the following standards:
 - i. The sign is installed on a gabled, hipped, mansard, or otherwise sloped roof;
 - ii. Sign area for the roof sign shall not exceed eight percent of the roof elevation area, with a maximum area of 120 square feet;
 - iii. The highest point of the roof sign shall not exceed the height of the ridge of the roof; and
 - iv. Issuance of a building permit and final approval of the installed sign by the building department.

B. Maximum Sign Height.

- 1. Monument signs shall be no more than six feet in height.
- 2. Ground-mounted signs shall be no more than 12 feet in height.
- 3. Pole signs in a major or minor business complex shall not exceed the sign heights outlined in Section XX.XX.105 of this chapter.

4. The overall height of a balloon sign, if installed on the ground, shall not exceed the height of the lowest building on the site. If installed on top of a building, the height of the balloon sign above the roof of the building shall not exceed a distance equal to the height of the building above grade.

XX.XX.070 Industrial sign district.

In addition to the temporary and permanent signage allowed without permits, the following signage is allowed subject to the requirements of this chapter:

Comment: In referencing specific types of uses within the districts, the drafter is cautioned to refer to the jurisdiction's zoning ordinance, and to either similarly define them in the sign code or at least by reference to the zoning/development code.

- A. Permitted Sign Types, Number and Area. Signs within the industrial sign district are limited as follows and require the obtaining of permits under Section XX.XX.130 of this chapter:

1. Monument Signs.

- a. Principal Use. One single- or double-faced monument sign shall be permitted for each lot along the primary street frontage. Where a use has multiple street frontages, this signage may be permitted along each building frontage that abuts a TSP designated arterial or collector street. Sign area shall not exceed 30 square feet for each sign face.
- b. Principal Use on Sites Larger Than Five Acres. One single- or double- faced monument sign shall be permitted for each lot along the primary street frontage. Where a use has multiple street frontages, this signage may be permitted along each building frontage that abuts an arterial or collector street. Sign area shall not exceed 60 square feet for each sign face.
- c. Churches, Schools and Public/Semipublic Facilities. One single- or double-faced monument sign shall be permitted for each such facility. Where such a facility has multiple street frontages, this signage may be permitted on each frontage. Sign area shall not exceed 30 square feet for each sign face.

2. Wall Signs. Principal Use. The total sign face area for building-mounted wall signs shall not exceed eight percent of the building elevation area on the primary frontage, with a maximum individual sign face area of 100 square feet. Where the use has multiple building frontages, the total signage on secondary building frontages shall not exceed six percent of the building elevation area with a maximum individual sign face area of 100 square feet. However, if the building elevation area on a frontage exceeds 5,000 square feet, the maximum individual sign area may increase to 199 square feet.

3. Bulletin Boards. Churches, Schools and Public/Semipublic Facilities. One single- or double-faced bulletin board may be incorporated into an approved monument sign. Maximum sign area for the bulletin board shall not exceed 24 square feet for each sign face.
4. Banner Signs.
 - a. Principal Use. One banner sign shall be permitted for each principal use and shall be limited to a display period of a maximum of 30 continuous days twice during the calendar year. Maximum sign area shall not exceed 50 square feet.
 - b. Temporary Business. One banner sign shall be permitted for a temporary business and shall be allowed for the same duration as the temporary business. Maximum sign area shall not exceed 50 square feet for a banner sign.
5. Signs with a Dynamic Element. Dynamic elements on signs are allowed in an Industrial Sign District subject to the prohibitions in Section XX.XX.030 and the following conditions in this section.
 - a. Dynamic elements are allowed only on one sign per site.
 - b. Dynamic elements are allowed only on monument signs and pole signs.
 - c. Only one contiguous dynamic element is allowed on a sign face.
 - d. A dynamic element may not change or move more often than once every **[20 minutes]** except one for which more frequent changes are necessary to correct information.
 - e. The images and messages displayed must be static, and the transition from one static display to another must be instantaneous without any special effects.
 - f. The dynamic element may not be illuminated to a degree of brightness than is greater than necessary for visibility. Signs found to be too bright shall be adjusted or removed as directed by the **[City Manager]**.
 - g. Dynamic elements must be designed and equipped to freeze the element's display in one position if a malfunction occurs.
 - h. Sign area of the dynamic portion of the sign shall not exceed 50 percent of the total sign face.

6. Roof Signs.

- a. For a principal use, the **[City Manager]** may approve one roof sign, in lieu of other building-mounted signs, only upon finding that there are no other reasonable means of signing the business or use, due to extraordinary circumstances related to the physical location or structure of the building, distance from nearby streets, proximity of surrounding buildings or vegetation, or other factors over which the applicant has no control.
- b. Approval of a roof sign shall be subject to the following standards:
 1. The sign is installed on a gabled, hipped mansard, or otherwise sloped roof;
 2. Sign area for the roof sign shall not exceed eight percent of the roof elevation area, with a maximum area of 120 square feet;
 3. The highest point of the roof sign shall not exceed the height of the ridge of the roof; and
 4. Issuance of a building permit and final approval of the installed sign by the building department.

B. Maximum Sign Height. Monument signs shall be no more than six feet in height.

C. Illumination. The illumination of signs within the industrial sign district shall meet the standards contained in Section XX.XX.125 of this chapter.

XX.XX.075 Billboard districts and permits.

- A. No billboard shall be constructed or maintained within the city unless the owner obtains a billboard permit from the **[City Manager]**. A billboard permit is a type of sign permit required under Section XX.XX.130 of this chapter.
- B. An owner of a billboard site may apply for a billboard permit as provided in Section XX.XX.130 of this chapter. The **[City Manager]** shall issue or deny the billboard permit within 30 days of receipt of the permit application. If there are more complete applications for a billboard permit than there are billboard permits available to issue, the **[City Manager]** must give preference to the earlier-submitted complete applications. A billboard permit shall be issued under the provisions of Sections XX.XX.130 and XX.XX.140 of this chapter.
- C. A billboard permit is subject to the following standards:

1. A billboard must be located within the boundaries of **[list]** district.
2. No more than 16 billboard permits shall be issued at any one time for billboards within the **[list]** district. The number of billboard permits within the **[list]** district may be increased by the number of any billboards located on land designated industrial or commercial in the city's comprehensive plan, located adjacent to **[street/highway name – define scope of area]**. No more than two billboard permits shall be issued at any one time for billboards within the **[list]** district. The **[City Manager]** shall limit the number of billboard permits within the **[list]** billboard district to one permit if that permit allows a tri-vision sign or an electronic message sign. The **[City Manager]** shall also limit the number of billboard permits within the **[list]** billboard district if consolidation is approved under subsection (C)(11) of this section.
3. A billboard permit may be assigned without the consent of the city. The permittee shall provide notice of any assignment to the city. The allowed location of a billboard may be changed by modification of the permit. The **[City Manager]** shall approve a modification if the new location is consistent with the requirements of this section of the code.
4. Except as provided herein and in subsection (C)(11) of this section, each sign face of a billboard shall not exceed 300 square feet in area. The signage area may be increased an additional 20 percent for any signage that is irregular in form and projects beyond the outer dimensions of the sign board, frame or cabinet. Each side of a double-faced billboard shall be a separate sign face for purposes of these signage area limitations.
5. Dynamic elements on signs and tri-vision signs are allowed in a Billboard District subject to the prohibitions in Section XX.XX.030 and the following conditions in this section.
 - a. Dynamic elements are allowed only on one sign per site.
 - b. Dynamic elements are allowed only on monument signs and pole signs.
 - c. Only one contiguous dynamic element is allowed on a sign face.
 - d. A dynamic element may not change or move more often than once every **[20 minutes]** except one for which more frequent changes are necessary to correct information.
 - e. The images and messages displayed must be static, and the transition from one static display to another must be instantaneous without any special effects.

- f. The dynamic element may not be illuminated to a degree of brightness than is greater than necessary for visibility. Signs found to be too bright shall be adjusted or removed as directed by the **[City Manager]**.
 - g. Dynamic elements must be designed and equipped to freeze the element's display in one position if a malfunction occurs.
 - h. No tri-vision sign of electronic message sign may be located within the **[list]** billboard district until or unless the number of billboard permits for that district is limited to one permit.
- 6. Any billboard may be double-faced, allowing sign copy on two sides of a sign structure, provided the two sides are parallel to each other within a deviation of ten degrees.
 - 7. The building height zoning limitation for the property upon which a billboard is situated applies to that billboard.
 - 8. Within the **[list]** billboard district, no billboard shall be located closer than 150 linear feet from the property line of any residentially zoned property as measured along the same side of the highway and at the highway frontage where a sign is proposed, unless the residential property is separated from the billboard property by **[highway name]**.
 - 9. All billboards shall be subject to the separation requirements established by state statute or rule.
 - 10. The provisions of this section control over any inconsistent requirement or limitation in the underlying sign district applicable to the property on which a billboard is located.
 - 11. Within the **[list]** billboard district, a billboard permit holder may file a consolidation application to combine two billboards with areas less than 300 square feet into one billboard with an area less than 700 square feet. The **[City Manager]** shall approve the billboard consolidation application if the consolidated billboard meets the locational standards in subsections (C)(8) and (C)(9) of this section. In the event a billboard permit holder receives a consolidated billboard permit, the number of permits allowed within the billboard district shall be permanently decreased by the number of consolidated permits issued.
 - 12. No person installing a billboard shall scatter, daub, or leave any paint, paste, glue, or other substances used for painting or affixing advertising matter or scatter or throw or permit to be scattered or thrown any bills, waste matter, paper, cloth, or materials of whatsoever kind removed from signs on any public street, sidewalk, or

private property.

XX.XX.080 Measurements.

The following shall be used in measuring a sign to determine compliance with this chapter:

A. Sign Area.

1. Sign area shall be measured within lines drawn between the outermost dimensions of the frame or cabinet surrounding the display area containing the sign copy. When signs are not framed or on a base material and are inscribed, painted, printed, projected or otherwise placed upon, or attached to a building, canopy, awning or part thereof, the sign area is the smallest possible space enclosing the sign copy that can be constructed with straight lines. Where a sign is of a three-dimensional, round, or irregular solid shape, the largest cross-section shall be used in a flat projection for the purpose of determining sign area.

2.

TABLE [XX]

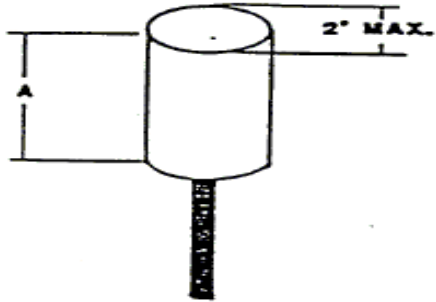
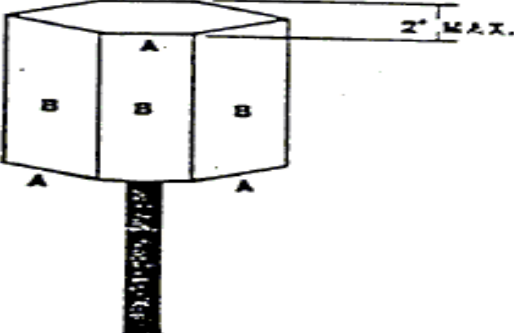
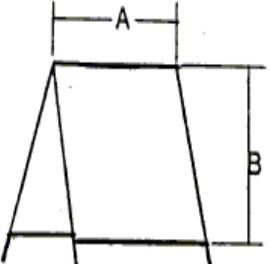
 <p>TOTAL AREA= (A)XCIRCUMFERENCE(2TR)</p>	 <p>TOTAL AREA= (A)(B)+(A)(B)+(A)(B), ETC.</p>
 <p>TOTAL AREA = (A)(B)</p>	

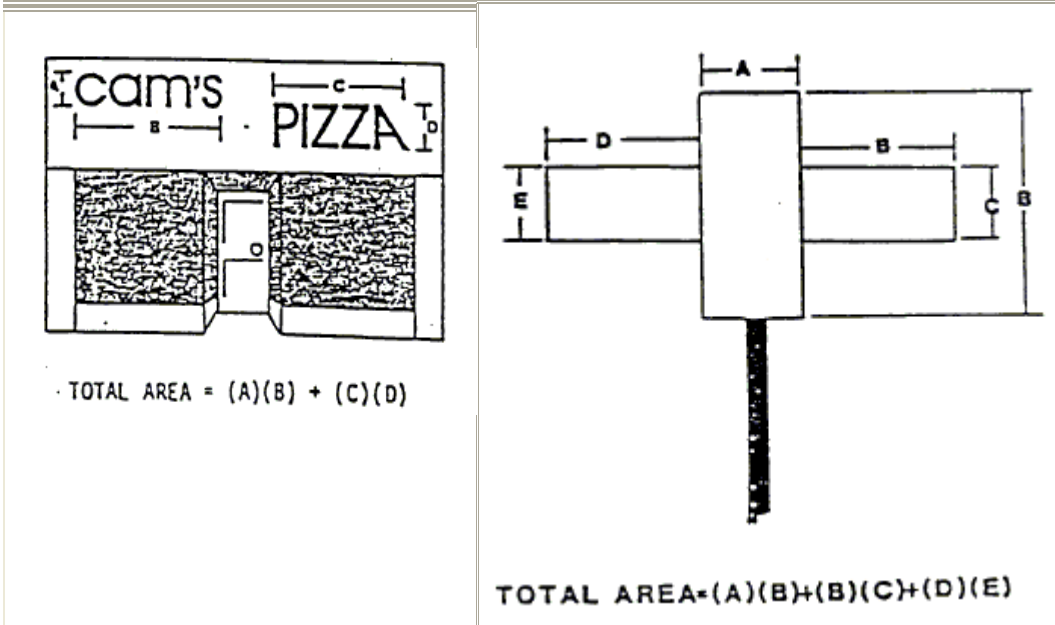
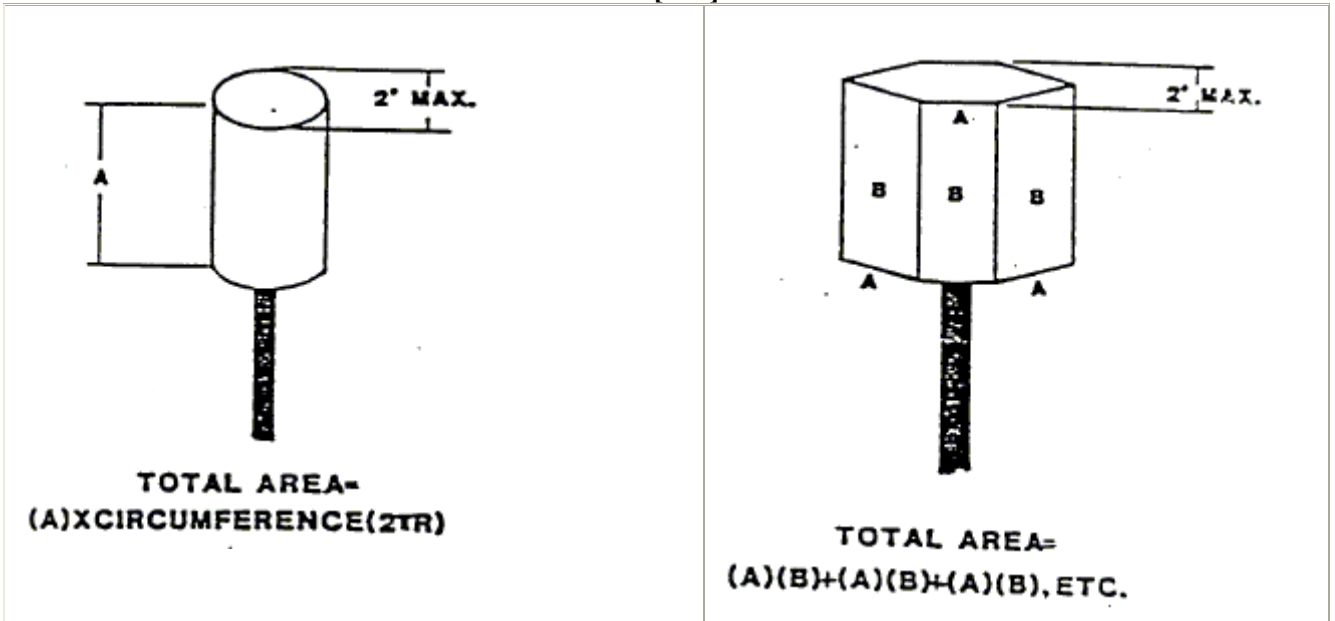
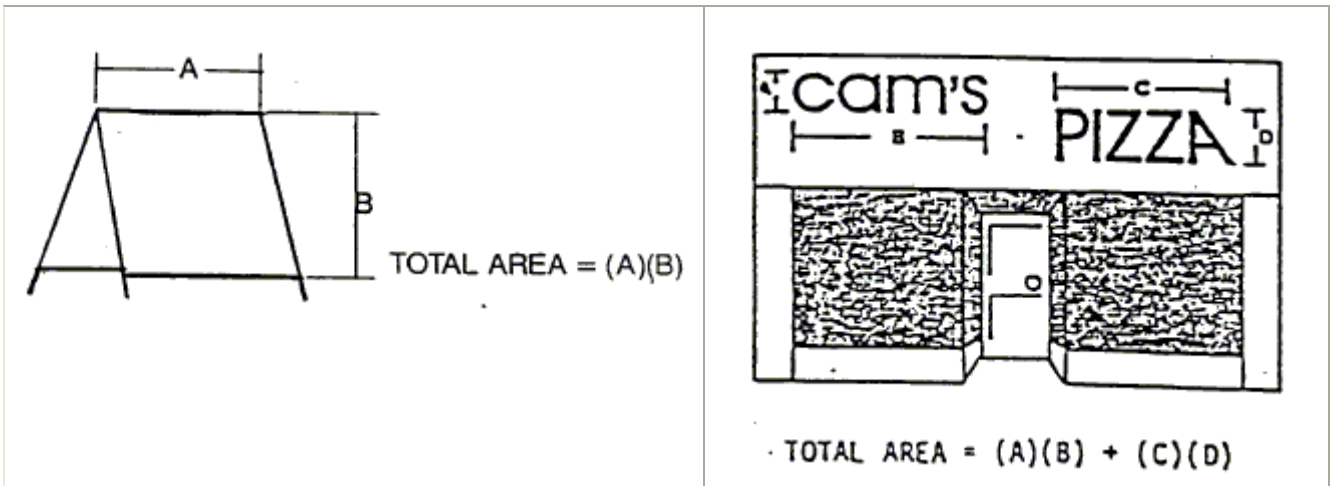

TABLE [XX]





3. The area of all signs in existence at the time of enactment of the ordinance codified in this chapter, whether conforming or nonconforming, shall be counted in establishing the permitted sign area.
4. When signs are constructed in multiple separate pieces containing sign copy, sign face area is determined by a perimeter drawn in straight lines, as small as possible, around all pieces.

B. Height.

1. Height of sign above grade is measured from the average level of the grade below the sign to the topmost point of the sign including the supporting structure.
2. Where there is a limitation on the size of lettering, the lettering shall be measured cumulatively in height. See graphic below.

**TABLE [XX]
METHOD OF MEASURING HEIGHT OF LETTERING FOR
CORNICE SIGNS**

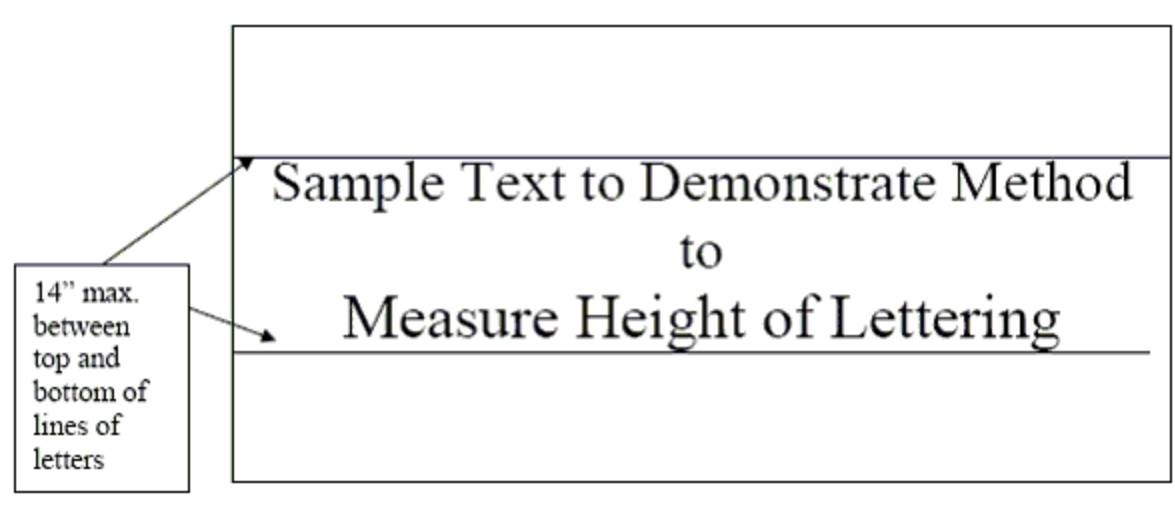

C. Clearance. Clearance is measured from the average grade below the sign to the lowermost point of the sign.

D. Spacing.

1. For the purpose of applying spacing requirements to signs, distances shall be measured parallel to the centerline of the adjacent street or highway.
2. The sign or sign location under consideration shall be included as one sign.
3. A back-to-back sign is counted as a single sign for the purpose of spacing distances.

[E. **Visibility.**]

Comment: Some jurisdictions may wish to attempt to regulate the visibility of the signs vis-à-vis other signs. These should be carefully thought out because there are likely challenges in the administration and enforcement.

XX.XX.085 Projecting signs.

An otherwise authorized sign shall be permitted to project over public right of way if the sign meets all of the following requirements:

- A. The sign is attached to the face of a building where the building face is located within five feet of the property line abutting a street.

- B. No external cross braces, guy wires, trusses, or similar bracing systems are used in constructing the sign.
- C. The sign extends no more than eight feet from the building face and shall be no less than 8.5 feet above the ground under the projecting sign.
- D. The sign does not project above the roof line or parapet wall, whichever is higher.
- E. Projecting signs shall conform to all provisions of this section which are designed to provide safe minimum clearance along public sidewalks and streets. The setback of the outer edge of the projecting sign must be a minimum of two feet from the curbline.
- F. Spacing between an earlier erected and any later erected projecting sign shall be a minimum of 20 feet.

Comment: Only applicable if the jurisdiction imposes a spacing requirement, see XX.XX.080.E.

XX.XX.090 Wall signs.

- A. A wall sign shall not project more than 18 inches from the wall to which it is attached. A wall sign located on an alley frontage shall not project more than 12 inches from the wall to which it is attached and shall have 15 feet of clearance.
- B. A wall sign shall not project above the roof line, or top of the parapet wall, whichever is higher.
- C. No external braces, guy wires, “A” frames, or similar bracing systems shall be used in constructing a wall sign.
- D. The height of a wall sign attached to the end or face of a marquee shall not exceed 30 inches. The lower edge of the sign shall not extend below the marquee.
- E. Wall signs on mansard roofs of 30 degrees or less may be installed vertically if solid background is used.
- F. Wall signs shall be placed within the sign band.

XX.XX.095 Freestanding signs.

- A. No part of a freestanding sign shall be erected or maintained within three feet of a street front property line, or within five feet of a side lot line, unless the application for the permit has been reviewed by the fire marshal and the fire marshal has determined that the

location of the sign does not interfere with adequate fire access to any property.

- B. No part of a freestanding sign shall project or extend into any public right of way.
- C. Except as provided in this subsection, no freestanding sign shall project or extend into any vision clearance area. One or two sign poles supporting a freestanding sign may be located within the vision clearance area if they are necessary for the support of the sign, and if no other portion of the sign is located within the vision clearance area between two feet and ten feet over grade.
- D. A freestanding sign shall be directly supported by poles or foundation supports in or upon the ground. No external cross braces, guy wires, "T" frames, "A" frames, "trusses," or similar bracing systems shall be used to buttress, balance, or support a freestanding sign.
- E. Only one freestanding sign is allowed for each street frontage.
- F. A minimum of nine feet in clearance is required in areas accessible to vehicles. The lowest point of these signs may be less than nine feet above grade in areas not accessible to vehicles when the signs are protected from physical damage by the installation of bumper poles or other ground protections.
- G. Freestanding signs permitted in a commercial sign district or industrial sign district shall not be located closer than 50 linear feet from the property line of any single-family residential, multifamily residential, or station community residential zoned property as measured along the street frontage.

XX.XX.100 Awning signs.

- A. Awning signs are permitted only as an integral part of the awning to which they are attached or applied.
- B. The awning supporting structure shall maintain a clearance of 8.5 feet.
- C. An awning shall not extend to within two feet from the curb. An awning shall not project above the roof line.
- D. The awning sign shall extend no more than eight feet from the building face.

XX.XX.105 through 115 Reserved

XX.XX.120 Construction and maintenance standards.

- A. All permanent signs shall be constructed and erected in accordance with the requirements of the State Building Code.
- B. All illuminated signs must be installed by a state-licensed sign contractor, subject to the requirements of the State Electrical Code. All electrically illuminated signs shall be listed, labeled, and tested by a testing agency recognized by the state of Oregon.
- C. Building and electrical permits shall be the responsibility of the applicant. Prior to obtaining building and electrical permits, the applicant shall obtain a sign permit or demonstrate an exception from the permit requirements of this chapter.
- D. All signs, together with all of their supports, braces, guys, and anchors shall be kept in good repair and be maintained in a safe condition. All signs and the site upon which they are located shall be maintained in a neat, clean, and attractive condition. Signs shall be kept free from excessive rust, corrosion, peeling paint or other surface deterioration. The display surfaces of all signs shall be kept neatly painted or posted. Signs which are faded, torn, damaged or otherwise unsightly or in a state of disrepair shall be immediately repaired or removed.
- E. No sign shall be erected or maintained in such a manner that any portion of its surface or supports will interfere in any way with the free use of any fire escape, exit, or standpipe. No signs shall be erected or maintained so as to obstruct any building opening to such an extent that light or ventilation is reduced below minimums required by any applicable law or provisions of this code.

XX.XX.125 Illumination—General restrictions.

- A. No sign, light, lamp, bulb, tube, or device shall be used or displayed in violation of this section.
- B. Regardless of the maximum wattages or milliamperage rating capacities allowable under Section XX.XX.125(E) of this chapter, no light source shall create an unduly distracting or hazardous condition to a motorist, pedestrian or the general public. Lighted signs shall be placed, shielded or deflected so as not to shine into residential dwelling units or structures, or impair the road vision of the driver of any vehicle.
- C. External light sources for a sign shall be directed and shielded to limit direct illumination of any object other than the sign.
- D. Except for holiday seasonal decorations, temporary signs shall not be illuminated.

E. The illumination of signs shall comply with the following standards:

1. No exposed reflective type bulb, par spot nor incandescent lamp, which incandescent lamp exceeds **[25]** watts, shall be exposed to direct view from a public street or highway, but may be used for indirect light illumination of the display surface of a sign.
2. When neon tubing is employed on the exterior or interior of a sign, the capacity of such tubing shall not exceed **[300]** milliamperes rating for white tubing nor **[100]** milliamperes rating for any colored tubing.
3. When fluorescent tubes are used for interior illumination of a sign, such illumination shall not exceed:
 - a. Within residential sign districts, illumination equivalent to 400 **[25]** milliampere rating tubing behind a sign face with tubes spaced at least seven inches, center to center;
 - b. Within commercial or industrial sign districts, illumination equivalent to **[800]** milliampere rating tubing behind a sign face spaced at least nine inches, center to center.

XX.XX.130 Sign permit application.

- A. Except as provided in this chapter, a permit is required to erect, construct, repair or alter a sign. If a sign is for a new development that requires development review under **[City]** zoning/development, then the sign shall be reviewed as part of the development review process prior to approval of a sign permit.
- B. An application for a sign permit shall be made on a form prescribed by the **[City Manager]** and shall be filed with the city. The application shall be filed by the owner of the sign or a representative of the sign's owner. A separate sign permit application is required for each sign, unless a combined application for all signs in a proposed development is proposed. The application shall include information required by the **[City Manager]** and the following:
 1. A sketch of the site, drawn to scale, showing the approximate location of existing structures, existing signs, and the proposed sign;
 2. Building frontage elevations drawn to scale, showing the sign's relative location and placement;
 3. An illustration of the proposed sign, drawn to scale, showing the design, elevations, sign face dimensions and area, materials and engineering data which demonstrates its structural stability. The illustration of the proposed sign need not show the sign message, but shall show the size, style, and design of the lettering, numbers, and

graphics conveying any message. The content of any message shall not be considered in the evaluation of a sign permit application;

4. The names and addresses of the applicant, the owner of the property on which the sign is to be located, the manufacturer of the sign and the person installing the sign, and the construction contractor's board number of the installer. The owner of the property on which the sign is to be located shall sign the sign permit application;
5. A fee in the amount set by council resolution. When a person begins construction of a sign requiring a sign permit before the permit is approved, the permit fee shall be doubled.

C. When deemed necessary by the building official, building or electrical permits shall be obtained as a part of the sign permit process. When required by Section XX.XX.095 of this chapter, the approval of the fire marshal shall be obtained.

D. Public Notice of Sign Permit Application and Comment Period.

Comment: If Sign Permit review is a "limited land use decision" ("The approval or denial of an application based on discretionary standards designed to regulate the physical characteristics of a use permitted outright, including but not limited to site review and design review") and within an urban growth boundary, then the city must provide for at least 14-day written comment period by properties within 100 feet. ORS 197.195(3).

Notice is required to be given to the recognized neighborhood association in which the site is located. ORS 197.763(1)(b).

Notice must contain:

- *statement that issues that could be basis of appeal must be stated in written comment; list criteria; address;*
- *date/time/place comments are due;*
- *copies of application available for inspection/copying;*
- *name of staff person. ORS 197.195(3).*

It is recommended that the notice process be the same as for the city's zoning/development applications which are "limited land use decisions," for consistency.

E. The **[City Manager]** shall grant or deny the sign permit application based upon the information submitted with the application and other information obtained by or submitted to the city.

Comment: When setting up the application and appeal process, attention should also be given to the requirement for processing an application to a final decision within the 120-day period required by ORS 227.178.

Non-Land Use Regulation	Land Use Regulation
<p>A decision on a sign permit application shall be made within seven calendar days of submission of a complete application, unless a later decision period is specified under the below subsections.</p>	<p>A decision on a sign permit application shall be made within seven calendar days following completion of the Public Comment Period above, unless a later decision period is specified under the below subsections. The decision shall be based upon and accompanied by a brief statement that explains the criteria and standards considered relevant to the decision, states the facts relied upon in rendering the decision, and explains the justification for the decision based on the criteria, standards and facts set forth.</p>
<p><i>Comment: To exercise prior restraint (requiring a permit before erection of a sign), it is recommended that the time for application review and appeal provide for expeditious review. If review of application is content-neutral with objective criteria, quick time for review is not required. In <u>Granite State Outdoor Advertising, Inc. v. City of Clearwater</u>, 5-day completeness review and 5-10 working days substantive review deemed constitutional. In <u>Thomas v. Chicago Park</u>, 28 days was approved. <u>GK Travel</u> (14-day review).</i></p>	<p><i>Comment: Decision to be made following close of Comment Period. ORS 197.195(4) requires a statement explaining the decision. See also Non-Land Use Regulation Comment opposite.</i></p>

If a decision is not made within the time specified in this section, the applicant may temporarily install the sign as requested, at the applicant’s risk for costs of removal, until such time as the City’s decision is issued and is final.

F. Notice of Decision

Non-Land Use Regulation	Land Use Regulation
<p>If the application is denied, the [City Manager] shall mail the applicant written notice of the decision and shall explain why the application was denied. [The decision shall also include an explanation of the applicant’s appeal rights.] The decision shall be mailed to the address of the applicant on the application by regular mail.</p>	<p>The [City Manager] shall mail the applicant and any persons who submitted a written comment upon the application within the Public Comment Period written notice of the decision and shall explain why the application was approved or denied. The decision shall also include an explanation of the appeal rights. The decision shall be mailed by regular mail to the address of the applicant on the application and to interested persons to the address stated in their Comment.</p>
<p><i>Comment: The [bracketed text] is not required by statute.</i></p>	<p><i>Comment:</i></p> <ul style="list-style-type: none"> o <i>Decision must be based upon the submitted record and explain the justification for the decision. ORS 197.195(4).</i> o <i>Explanation of appeal rights required by ORS 197.195(4).</i>

G. A sign permit application shall be approved if:

1. The application complies with all of the applicable provisions of this chapter and any other objective requirement imposed by law. No standard shall be applied to deny a permit if the operation of that standard violates a constitutional right of the applicant. If, as part of the application, an applicant identifies a particular standard alleged to have unconstitutional effect, and provides reasons for that contention, the **[City Manager]** shall seek the opinion of the city attorney on the contention. If the city attorney concludes that the operation of the standard violates a constitutional right of the applicant, the **[City Manager]** shall not apply the standard in reviewing the application;
2. The applicable permit fee has been paid.

H. An approved sign shall be constructed and installed within six months of the final approval of the permit, including resolution of any appeal. The sign permit shall be void if

installation is not completed within this period or if the sign does not conform to the approved permit. Sign permits mistakenly issued in violation of this chapter or other provisions of this code are void. The **[City Manager]** may grant a reasonable extension of time for the installation deadline upon a showing of reasonable grounds for delay.

- I. If sign does not conform to the building code after inspection, the sign will be subject to removal under Section XX.XX.165 of this chapter.
- J. The **[City Manager]** may revoke a sign permit if **[he/she]** finds that there was a material and misleading false statement of fact in the permit application.

XX.XX.135 Adjustments.

- A. Adjustments to the numeric standards of this section shall be allowed only in compliance with this subsection. Adjustments may be requested to allow relocation of a sign, on the subject property, reducing the height of a sign, or enlarging the area of a sign. Adjustments allowing the use of prohibited signs, or allowing signage other than that specifically allowed by this code, are not permitted.
- B. Requests for adjustments shall be filed with the city, on a form provided by the planning department, and accompanied by a fee as approved by the city council. The request shall include the information required for a sign permit, as specified in Section XX.XX.130 of this chapter, the specific standard from which the adjustment is requested, and the numeric amount of the adjustment, and written responses to the following approval criteria:
 - 1. Strict application of the code requirement would deny the applicant a reasonable opportunity to communicate by sign in a manner similar to like persons or uses because of an unusual or unique circumstance relating to the property or the proposal, such as site or building location, building design, physical features on the property, or some other circumstance;
 - 2. The sign which would result from the variance will not affect the surrounding neighborhood or other property affected by the request in a manner materially inconsistent with the purpose of the Sign Code as stated in XX.XX.010; and
 - 3. The degree of the variance is limited to that reasonably necessary to alleviate the problem created by the unique or unusual circumstance identified pursuant to subsection (1) of this section.
- C. The **[hearing body]** shall conduct a public hearing on the request for adjustment. The **[hearing body]** shall approve, approve with conditions, or deny the adjustment, based upon the evidence at the hearing. The **[hearing body]** may impose such conditions as are deemed necessary to mitigate any adverse impacts which may result from approving the adjustment. The hearing shall be conducted under the procedures used by the

[hearing body] for a quasi-judicial land use hearing.

- D. The city recorder shall give written notice of the hearing by mail to owners of property located within 100 feet of the lot containing the sign, using for this purpose names and addresses of owners as shown upon the latest assessment role of the county assessor. Failure of a person to receive the notice specified in this section shall not invalidate any proceeding in connection with the application for an adjustment.

Comment: Some jurisdictions expand the notice area beyond the statutory minimum of 100 feet. ORS 197.797(2)(a) [formerly ORS 197.763(2)(a)]. Notice to neighborhood associations is required by ORS 197.797(2)(b) [formerly ORS 197.763(2)(b)].

Comment: If the sign code is a land use regulation, the notice of decision area should be the same as for a limited land use decision (variance) under the development code.

- E. The **[hearing body]** shall issue its decision in writing explaining the reasons why the adjustment was approved or denied. The decision shall be mailed to the address of the applicant on the application by regular mail. The decision of the **[hearing body]** shall be final.

XX.XX.140 Appeal of decision on sign permit.

Non-Land Use Regulation	Land Use Regulation
<p>An applicant may appeal the denial of an application for a sign permit, conditions of approval of the allowance of a permit or revocation of the permit.</p> <p>An appeal may be initiated by filing a form prescribed by the [City Manager], that is filed within 20 days of the date of mailing the decision of the [City Manager]. The form shall specify the basis for the appeal.</p> <p>Except as provided herein, the appeal shall be to the [hearing body]. The decision of the [hearing body] may be appealed to the city council.</p>	<p>An applicant or interested person who appeared by submission of a comment may appeal the denial of an application for a sign permit, conditions of approval of the allowance of a permit, or revocation of the permit.</p> <p>An appeal may be initiated by filing a form prescribed by the [City Manager], that is filed within 20 days of the date of mailing the decision of the [City Manager], city engineer or the building official.</p> <p>Except as provided herein, the appeal shall be to the [hearing body].</p>

<p><i>Comment: A decision of approval or denial should be in writing, with a copy provided to the applicant. <u>Café Erotica</u> (concurring opinion); <u>GK Travel</u></i></p> <p><i>To exercise prior restraint (requiring a permit before erection of a sign), it is recommended that the time for appeal provide for expeditious review. <u>Granite State Outdoor Advertising, Inc. v. City of Clearwater</u>, <u>Thomas v. Chicago Park</u>, <u>GK Travel</u></i></p>	<p><i>Comment: At least one internal appeal required from hearing officer’s decision to the planning commission or to the City Council is required, if the initial decision is made without a hearing. ORS 227.175(10)(a)(A).</i></p> <p><i>Comment: See ORS 227.010 - .090 to determine if other hearings bodies within the jurisdiction qualifies as a “Planning Commission.” Appeal could be directly to city council. ORS 227.175(10)(a)(D).</i></p>
	<p>The hearing before the [hearing body] shall be de novo, and is not limited to the issues stated in the appeal notice.</p>
	<p><i>Comment: ORS 227.175(10)(a)(D) and (E) require the initial post-hearing officer hearing be de novo, without limitation of evidence or argument to what was reviewed by the hearings officer.</i></p>
	<p>The decision of the [hearing body] may be appealed to the city council.</p>
	<p><i>Comment: Only one internal appeal is required; the hearing body’s decision could be the final decision of the City. If the sign code is considered a land use regulation, refer to similar provisions in the jurisdiction’s development code. [In setting the application processing times and hearing notice requirements, keep in mind the 120-day limitation for processing land use permits].</i></p>

Non-Land Use Regulation	Land Use Regulation
	The city recorder shall give written notice of the hearing by mail to owners of property located within 100 feet of the lot containing the sign, using for this purpose names and addresses of owners as shown upon the current records of the county assessor, and to the recognized neighborhood association in which the site is located. Failure of a person to receive the notice specified in this section shall not invalidate any proceeding in connection with the application for an appeal.
<i>Comment: The extent of public notice of an appeal hearing is up to the City, as the focus under the First Amendment is only upon the speaker's rights. Some jurisdictions may elect to involve the public, and issue public notices of hearings, akin to land use hearings.</i>	<i>Comment: Again, some jurisdictions expand the notice area beyond the statutory minimum of 100 feet. ORS 197.797(2)(a) [formerly ORS 197.763(2)(a)]. Notice to neighborhood associations is required by ORS 197.797 (2)(b) [formerly ORS 197.763(2)(b)].</i>

A. The **[hearing body]** shall conduct a public hearing on the appeal within 21 days following the receipt of the filed notice of appeal.

Comment: To exercise prior restraint (requiring a permit before erection of a sign), it is recommended that the time for appeal provide for expeditious review. Granite State Outdoor Advertising, Inc. v. City of Clearwater, Thomas v. Chicago Park, GK Travel

The **[hearing body]** shall grant or deny the permit based upon the evidence at the hearing and the record of its administrative proceedings.

Non-Land Use Regulation	Land Use Regulation
The hearing may be conducted under the procedures used by the [hearing body] for a quasi-judicial hearing.	The hearing shall be conducted under the procedures used by the [hearing body] for a quasi-judicial land use hearing.
	<i>Comment: The initial evidentiary hearing procedures of ORS 197.797 [formerly ORS 197.763] must be followed. See also ORS 197.195(5).</i>

- B. The **[hearing body]** shall issue its decision in writing explaining the reasons why the permit was granted or denied.

Non-Land Use Regulation	Land Use Regulation
The decision shall be mailed to the address of the applicant on the application by regular mail.	The decision shall be mailed by regular mail to the address of the applicant on the application and to interested persons to the address stated in their Comment.

Municipal Court Option
<p>In considering the appellant’s contentions, the [hearing body] shall exercise only the following review authority:</p> <ol style="list-style-type: none"> 1. Determining whether the [City Manager] failed to follow applicable procedures in taking action on the permit or the sign in ways that prejudiced the rights of the appellant; 2. Determining whether the [City Manager] properly applied the provisions of this chapter; 3. Modifying the decision of the [City Manager] only to the minimum extent necessary to be consistent with the requirements of this chapter or of other laws; 4. Attaching such conditions to granting all or a portion of any appeal as necessary to achieve the purposes of this chapter. <p>When the appeal form in an appeal of a sign permit or revocation states an issue involving the application of state or federal constitutional law, the municipal court judge shall resolve the constitutional law issues on an expedited basis. Notice of the hearing before the municipal court judge shall be provided as set forth in this section. The court shall conduct a public hearing on the constitutional issues and may allow the reception of factual evidence. The city attorney may appear on behalf of the city. Following the hearing, the court shall issue a written opinion on the constitutional issues. If the constitutional issues are the only issues raised in the appeal, the court shall direct the [City Manager] to grant or deny the permit or revocation. The directed decision of the [City Manager] is the final decision of the city. If other issues are raised in the appeal, the decision of the municipal court shall be binding on the [hearing body]. Following resolution of these other issues, the decision of the [hearing body] may be appealed to the city council.</p> <p><i>Comment: The drafter should consider whether the appeal should be bifurcated between the constitutional issues (if any) and the non-constitutional issues, with the Municipal Court hearing the constitutional issues.</i></p>

XX.XX.145 Inspections.

- A. If a building permit is required, the building official shall perform a sign inspection upon notification by the permittee that the construction is ready for inspection. Failure of the permittee to notify the building official of the progress of construction for inspection purposes shall result in the revocation of the sign permit. A final inspection of a sign shall be made upon completion of all construction work and prior to its illumination.

- B. All signs may be inspected or reinspected at the discretion of the building official. The building official may inspect footings for monument, ground-mounted or freestanding signs. The building official may enter at reasonable time upon the premises of any person licensed under the provisions of this chapter for the purposes of inspection of signs under construction.

XX.XX.150 Enforcement of Sign Code – General Provisions

Comment: It can be difficult to enforce sign codes. The defendant in such cases often points to other instances in the City where violations have occurred and have not been enforced. This leads to arguments that the city is selectively enforcing its ordinance in violation of Article 1 Section 8 (free expression) and Article 1 Section 20 (equal privileges) of the Oregon Constitution and the First Amendment as well as the Equal Protection and Due Process under the Fourteenth Amendment of the US Constitution.

The basic elements of this claim are 1) that there is selectivity in enforcement; 2) that the selective enforcement is intentional; and 3) that the selective enforcement is based on an unjustifiable standard. City of Portland v. Bitans, 100 Or App 297, 302 (1990); McQuillin, Municipal Corporations Section 27.57.10. The argument that others have not been prosecuted is not sufficient. Selectivity in enforcement is allowed unless there is proof that it was deliberately pursued because of some impermissible reason such as race, religion or some other arbitrary standard. Proof of sporadic or non-existent enforcement in the past is not adequate.

In Oregon, these challenges to enforcement have generally failed. City of Eugene v. Crooks, 55 Or App 351 (1981).

The proposed code allows for monetary penalties and the recovery of costs for both signs on right of way and private property that are taken down by the City.

- *On private property, before the sign can be taken down and the owner charged, there should be notice and an opportunity for a hearing.*
- *On public property, non-permitted signs can be summarily removed and the owner given notice before the property is destroyed. Some codes and some jurisdictions merely remove the signs and destroy them. To avoid issues regarding the taking of private property, notice is proposed to be given before the property is destroyed.*

- A. The following referenced code sections may be utilized for enforcement of this Sign Code, in regards to the types of sign violations referenced:
1. Sign in public right of way or on City-owned real property: Section XX.XX.155.
 2. Sign on private property or on non-City-owned public property, other than on public

right of way: Section XX.XX.160.

3. Unsafe Sign: Section XX.XX.165.

4. Abandoned Sign: Section XX.XX.170.

- B. In addition to any other provisions contained herein, the **[City Manager]** is authorized to undertake such action as the **[City Manager]** deems necessary and convenient to carry out the provisions of this Sign Code, as is permitted by law.
- C. Nothing contained herein shall preclude the issuance of citations for civil violations of this ordinance, either prior to, concurrently with, or after action is commenced to declare a sign to be unlawful or to remove an unlawful sign.
- D. The **[City Manager]** may promulgate reasonable rules and regulations necessary to carry out the provisions of this chapter.
- E. When a sign is removed, altered, and/or stored under these enforcement provisions, removal and storage costs may be collected against the sign owner and the person responsible for the placement of the sign. The city council shall establish the fees for removal and storage of signs, and for other associated fees, by resolution, from time to time.
- F. This chapter shall not be construed to create mandatory enforcement obligations for the City. The enforcement of this chapter shall be a function of the availability of sufficient financial resources consistent with adopted budgetary priorities and prosecutorial priorities within the range of delegated discretion to the **[City Manager]**.

Comment: Just because a city prosecutes one violation and not another is not in itself prohibited discrimination. In the example of the sign code violation, unless the city is actually prosecuting a sign code because of the content of the message or because of membership in suspect class, there would be no improper prosecution. See also Medford Assembly of God v. City of Medford, 72 Or App 333, 339 (1984).

XX.XX.155 Enforcement – Sign in public right of way or on City-owned real property.

Any sign installed or placed in the public right of way or on City-owned real property, except in conformance with the requirements of this chapter, may be removed by the **[City Manager]** as follows:

- A. Immediate confiscation without prior notice to the owner of the sign.
- B. The city shall store any sign ordered to be removed by the **[City Manager]** for a period of **[30]** days from the time the person responsible therefore is notified as provided in this

subsection.

- C. The city shall continue to store such sign for any additional period during which an appeal or review thereon is before the **[City Manager / municipal court]**.
- D. If a telephone number or address of the owner of the sign, person responsible therefore, or person or business that is the subject of the communication on the sign in on the text of a sign, the City shall contact the said person or business by telephone or by mail (based on the manner of contact stated on the sign) and advise that the City believes that:
 - 1. The sign was found in a location that the City believes to be a public right of way or City-owned real property; and
 - 2. That no permit was issued for the placement of the sign in said location, and that the sign is not otherwise lawfully permitted to be in said location.
- E. The communication shall advise said person or business that the City has confiscated the sign and shall destroy the sign after **[30]** days from the time the person responsible therefore is notified, unless either the sign is claimed and the removal and notice fees are paid in full or a Request for Hearing is submitted by the reputed sign owner to the **[City Manager]**.
- F. If no telephone number or mailing address is stated for the owner of the sign on the sign, the City shall retain the sign for a period of **[15]** days to permit the sign owner to ascertain that the sign has been removed and to file a Request for Hearing.
- G. Upon receipt of a Request for Hearing, the City Recorder shall determine that the applicable fee is paid, and shall then schedule a hearing before the **[City Manager / municipal judge]** within **[3]** business days. The City Recorder shall notify the reputed sign owner and the appropriate city staff of the date, time, and place of the hearing upon the removal of the sign.
- H. The hearing shall be conducted by the **[City Manager / municipal judge]**. The procedures for the hearing shall be established by the **[City Manager / municipal judge]** sufficient to provide the parties not less than the minimum due process required under state and federal law.
- I. A prima facie violation of this Code shall be met if it is shown that:
 - 1. The sign was located in a public right of way or City-owned real property; and
 - 2. The sign owner is not a public entity or other public entity authorized to install and maintain public signs within the public right of way under this Sign Code.
- J. The sign owner may rebut the prima facie showing of violation upon a showing that the

sign was lawfully permitted within the public right of way or City-owned real property, or that the law does not require the sign owner to obtain a permit under this Sign Code to place a sign within the public right of way or on City-owned real property.

- K. The **[City Manager / municipal judge]** shall issue a written decision within **[7]** days following close of the hearing. The decision shall be based upon substantial evidence in the record. A copy of the decision shall be mailed to the reputed sign owner at such address as provided on the Request for Hearing. The decision of the **[City Manager / municipal judge]** shall be the final decision of the City.

- L. If the **[City Manager / municipal judge]** determines that the sign was not lawfully placed upon the public right of way or City-owned real property, then, following any applicable appeal or review period, the sign shall be destroyed in such manner as the **[City Manager]** determines appropriate. Destruction of the sign is in addition to any penalties that may be imposed under separate proceedings for civil violation of this Sign Code.

Non-Land Use Regulation	Land Use Regulation
<i>Comment: If the decision is not a land use decision, the appeal period is 60 days, under the writ of review provisions of ORS 34.030.</i>	<i>Comment: If the decision is a land use decision, the appeal period to LUBA is 21 days from the date of the decision.</i>

Comment: Some jurisdictions may wish to provide the option of allowing the sign owner to recover the sign. The following alternative text is suggested:

At the expiration of the time specified in this section, if the person responsible for the sign or other interested person has not reclaimed the sign as provided herein, the **[City Manager]** may destroy the sign or dispose of it in any manner deemed appropriate. To reclaim any sign removed by the **[City Manager]**, the person reclaiming the sign shall pay the city an amount equal to the entire costs incurred by the **[City Manager]** as provided in subsection (I).

- M. If the **[City Manager / municipal judge]** determines that the sign was lawfully placed upon the public right of way or City-owned real property, then the City shall re-install the sign upon the same place that it was removed from within **[3]** business days of the issuance of the decision and the fee for Request for Hearing shall be refunded to the payor of the fee.

Comment: The City may wish to include its right to appeal from the decision. In that case, re-installation of sign should be delayed until the appeal period has passed.

N. Costs, as determined by Section XX.XX.150(E), shall be the responsibility of the sign owner and the person responsible for the placement of the sign, collectively and individually.

XX.XX.160 Enforcement – Sign on private property or on non-City-owned public property, other than on public right of way.

- A. The **[City Manager]** may order the removal of any sign erected or maintained on private property or on non-City-owned public property, other than on public right of way, in violation of the provisions of this chapter or other applicable provisions of this code. If necessary to enter the premises to inspect the sign, the **[City Manager]** shall seek an administrative warrant for entry to the premises.
- B. An order to bring a sign into compliance or to remove a sign shall be in writing and mailed or delivered to the owner of the sign, if known, and the owner of the building, structure or premises on which the sign is located, if the owner of the sign is not known.
- C. The order shall inform the owner of the sign, if known, and the owner of the building, structure or premises on which the sign is located, if the owner of the sign is not known, that the sign violates the regulations in this chapter and must be brought into compliance or be removed within **[60]** days of the date of the order, or such earlier date as shall be stated in the order. The order shall also state the reasons why the **[City Manager]** concludes the sign violates the regulations in this chapter and shall inform the owner of the sign, if known, and the owner of the building, structure or premises on which the sign is located, if the owner of the sign is not known, of the right to submit a Request for Hearing, to determine whether or not the sign is in violation of this Sign Code.
- D. A Request for Hearing shall be filed by the reputed owner of the sign, or owner of the building, structure or premises on which the sign is located, within **[15]** days following mailing or delivery of the order. The Request for Hearing shall be filed with the City Recorder.
- E. Upon receipt of the Request for Hearing, the City Recorder shall proceed in the manner specified in Section XX.XX.155(G), and a hearing shall be held, and decision issued, in the manner specified in Section XX.XX.155(H) through (N).
- F. A prima facie violation of this Code shall be met if it is shown that the sign:
 - 1. Does not conform to the requirements of this Code; or
 - 2. Is posted by a person that is not authorized to post the sign in the specific location.
- G. The prima facie showing of a violation may be rebutted upon a showing that the sign was lawfully permitted or authorized under this Code, or is otherwise required to be

installed and maintained by state or federal law.

- H. If the **[City Manager / municipal judge]** determines that the sign is not permitted or authorized by this Sign Code, or by other applicable state or federal law, then within **[10]** days following any applicable appeal or review period, the owner of the sign, or owner of the building, structure or premises on which the sign is located shall cause the sign to be removed, or altered in such a manner as to be made to conform to the requirements of this Sign Code. A sign which is not removed or altered in such a manner as to be made to conform to the requirements of this Sign Code, is defined as a public nuisance.

Comment: Some jurisdictions may wish to consider different periods for removing permanent v. temporary signs. Other jurisdictions may decide that an illegal sign should be removed, following, hearing, post haste, regardless of its classification.

- I. The **[City Manager]** may:
1. Exercise all rights and remedies to cause the removal of the sign, including but not limited to removal of public nuisance, injunctive order, or as otherwise existing under Oregon law; and/or
 2. Seek judgment against the owner of the land and the sign owner, individually, or collectively, for the removal and other costs pursuant to Section XX.XX.150(E), and may collect upon the judgment in the manner provided by Oregon law; and/or
 3. Seek such additional orders from a court of competent jurisdiction to permit entry upon the premises and removal of the sign.
- J. Costs, as determined by Section XX.XX.150(E), shall be the responsibility of the sign owner and the person responsible for the placement of the sign, collectively and individually. The costs shall be made a lien against the land or premises on which such sign is located, and may be collected or foreclosed in the same manner as liens otherwise entered in the liens docket of the City.

XX.XX.165 Removal of unsafe signs.

- A. If the **[City Manager]** finds that any sign by reason of its condition presents an immediate and serious danger to the public, the **[City Manager]** may, without prior written notice, order the immediate removal or repair of the sign within a specified period. The **[City Manager]** shall follow the procedures provided in Section XX.XX.160, subsections (B), (C), (D), (E), (H), except that the **[City Manager]** may shorten the time deadlines as reasonable, considering the risk to the public from the sign if the sign were to fail.
- B. If the **[City Manager / municipal judge]** determines that the sign presents an immediate

and serious danger to the public, then within such time as set by the **[City Manager / municipal judge]** the owner of the sign, or owner of the building, structure or premises on which the sign is located shall cause the sign to be removed, or altered in such a manner as to be made to eliminate the threat of death, injury, or damage to the public and its property. A sign which is not removed or altered in such a manner as to be made safe, is defined as a public nuisance. Once removed, the sign itself remains the property of its owner and may be retrieved by the owner upon proof of ownership within **[X]** weeks of its removal. The City reserves the right to dispose of or recycle signs that are not retrieved by the owner before this deadline.

- C. Costs, as determined by Section XX.XX.150(E), shall be the responsibility of the sign owner and the person responsible for the placement of the sign, collectively and individually. The costs shall be made a lien against the land or premises on which such sign is located, and may be collected or foreclosed in the same manner as liens otherwise entered in the liens docket of the City.

XX.XX.170 Removal of abandoned signs.

- A. An owner of a sign shall remove the sign when it is abandoned.
- B. The **[City Manager]** may order the removal of abandoned signs in the same manner as provided in Section XX.XX.160, and the procedures for requesting a hearing, and the decision issued, shall be as set forth therein.
- C. Abandonment of a sign shall be made when it is shown that:
 - 1. The sign is no longer used by the person who constructed the sign or the property where the sign is located is no longer used. The sign owner may rebut the prima facie showing of this ground of abandonment upon a showing that a reasonable effort is underway to continue the use of the property or sign.
 - 2. The sign has been damaged, and repairs and restoration are not started within 90 days of the date the sign was damaged, or are not diligently pursued, once started.
- D. Costs, as determined by Section XX.XX.150(E), shall be the responsibility of the sign owner and the person responsible for the placement of the sign, collectively and individually. The costs shall be made a lien against the land or premises on which such sign is located, and may be collected or foreclosed in the same manner as liens otherwise entered in the liens docket of the City.

XX.XX.175 Reserved.

XX.XX.180 Violations.

- A. It shall be a violation of this Code for any person to perform, undertake, allow, or suffer the following:
 - 1. Installation, creation, erection, suffering, or maintenance of any sign in a way that would create a nonconforming sign;
 - 2. Failing to remove any nonconforming signs within 60 calendar days after the expiration of the amortization period;
 - 3. Failing to remove any nonconforming sign after being ordered to do so.
- B. Continuing Violation. Each day of a continued violation shall be considered a separate violation when applying the penalty provisions of this Code.

XX.XX.185 Penalties and Other Remedies.

- A. The [municipal / circuit] court is empowered to hear and determine violations of this chapter.
- B. In addition to any other penalty of law, the municipal court or any other court of competent jurisdiction may issue a judgment necessary to ensure cessation of the violation, including but not limited to injunctive order and/or monetary penalty.
- C. Any person who places a sign on property in violation of this chapter shall be punishable by a fine not to exceed [XX] dollars.

XX.XX.190 Amendments.

Non-Land Use Regulation	Land Use Regulation
<i>Comment: The drafter should consider whether the Sign Code should contain an amendment process that requires greater public notice and comment than required for the city's regular ordinances, given the need for meaningful public participation.</i>	<i>Comment: The drafter should also comply with the required notice and adoption process required for land use regulations.</i>

TABLE OF CASES

Ackerley Communications, Inc., v. City of Portland, 12 Or LUBA 410 (1984).
Ackerley Communications of Northwest v. Krochalis, 108 F3d 1095, 1099 (9th Cir 1997).
Ackerley Communications, Inc. v. Multnomah County, 72 Or App 617(1985),
rev. dismissed, 303 Or 165 (1987).
Café Erotica of Florida, Inc. v. St. Johns County, Florida, 360 F3d 1274 (11th Cir 2004).
City of Austin v. Reagan National Advertising, 596 US 61 (2022).
City of Eugene v. Crooks, 55 Or App 351 (1981).
City of Portland v. Bitans, 100 Or App 297, 302 (1990).
Cotter v. City of Portland, 46 Or LUBA 612 (2004).
Desert Outdoor Advertising, Inc. v. City of Moreno Valley, 103 F3d 814 (9th Cir 1996).
Fidanque v. State by and Through Oregon Gov't Stds. & Practices Comm'n, 328 Or 1
(Or 1998).
Granite State Outdoor Advertising, Inc. v. City of Clearwater, 351 F3d 1112 (11th Cir 2003),
Reh'ing denied, 97 Fed. Appx. 908 (Table), 11th Cir 2004), *cert. denied*, 543 US 813
(2004).
G.K. Ltd Travel v. City of Lake Oswego, 436 F3d 1064 (9th Cir 2006)
Haug v. City of Newberg, 42 Or LUBA 411 (2002).
Lamar Cent. Outdoor, LLC v. City of Los Angeles, 245 Cal App 4th 610, 625, 199 Cal. Rptr.
3d 620, 630–31 (2016), *reh'g denied*, (Mar 29, 2016), *rev. denied* (June 8, 2016).
Lone Star Sec. & Video, Inc. v. City of Los Angeles, 827 F3d 1192 (9th Cir 2016).
Medford Assembly of God v. City of Medford, 72 Or App 333 (1984).
Media Art v. Tigard, 46 Or LUBA 61 (2003).
Metromedia Inc. v. City of San Diego, 453 US 490 (1981).
One World One Family Now v. City & County of Honolulu, 76 F3d 1009 (9th Cir 1996).
Outdoor Media Dimensions, Inc. v. Dept. of Transp, 340 Or 275 (2006).
Reed v. Town of Gilbert, 135 SCt 2218 (2015).
State v. Robertson, 293 Or 402 (1983).
Thomas v. Chicago Park District, 534 US 316 (2002).
Ward v. Rock Against Racism, 491 US 781 (1989).
